



City and County of San Francisco
Master Report

City Hall
1 Dr. Carlton B. Goodlett Place
San Francisco, CA 94102-4689

File Number: 090951	File Type: Communication	Status: Filed
Enacted:	Effective:	
Version: 1	Reference:	In Control: Board of Supervisors
File Name: Petitions and Communications		Introduced: 7/28/2009
Requester:	Cost:	Date Passed:

Comment	Title:
	<p>Petitions and Communications received from July 14, 2009, through July 20, 2009, for reference by the President to Committee considering related matters or to be ordered filed by the Clerk on July 28, 2009. From Southeast Community Facilities Commission, submitting the "Annual Statement of Purpose and Annual Report for FY 2008-2009." (1) From Budget and Finance Committee, submitting recommendations of the Budget and Finance Committee for amendment of budget items for FY 2009-2010. (2) From Office of Citizen Complaints, submitting quarterly reports for the second quarter of 2009. Copy: Each Supervisor (3) From Office of the Clerk of the Board, submitting list of sole source contracts received from various city departments entered into during FY 2008-2009. (4) Adult Probation Asian Art Museum Human Resources Mayor's Office Public Defender Public Health From Nancy Wuerfel, regarding alleged flaw in the Interim Consolidated Budget and Annual Appropriation Ordinance, under Section 12.20 "Generally Accepted Principals of Financial Statement Presentation." (5) From Office of the Mayor, submitting the reappointment of Kimberly Brandon as a member of the Port Commission, term ending on May 1, 2013. Copy: Rules Clerk (6) From Office of the Mayor, submitting the reappointment of Larry Martin as a member of the Recreation and Parks Commission, term ending June 27, 2013. (7) From Office of the Mayor, submitting the reappointment of David Lee as a member of the Recreation and Parks Commission, term ending June 27, 2013. (8) From Office of the Mayor, submitting appointment of Amelia Yaros as a member of the Residential Rent Stabilization and Arbitration Board, term ending October 1, 2011. (9) From Office of the Mayor, submitting the reappointment of Dennis Normandy as a member of the Civil Service Commission, term ending June 30, 2013. (10) From Golden Gate Park Preservation Alliance, submitting opposition to proposed ordinance that would charge a fee for parking in Golden Gate Park. File No. 090716, Copy: Each Supervisor (11) From Public Library-Finance Department, submitting report on gifts up to \$10,000 received by the Public Library during FY 2008-2009. (12) From Sam Sirhed, submitting opposition to the formation of the "Greater Union Square Business Improvement District." File No. 090870, Copy: Each Supervisor (13) From Office of the Controller, regarding proposed ordinance that allows the Recreation and Park Department to enter into a naming agreement for the City-owned sports stadium located at Candlestick Point. File 090631, Copy: Each Supervisor (14) From the Department of Building Inspection, submitting copy of letter sent to constituent regarding the Department of Building Inspection's Dimensional Tolerance Policy. (15) From Office of Clerk of the Board, submitting Form 700 Statement of Economic Interest for Michael Stover-Fiscal Officer-leaving. (16) From Human Services Agency, submitting report on gifts up to \$10,000 received by the Human Services Agency during FY 2008-2009. (17) From Office of the Treasure, submitting investment activity (for fiscal year to date) of the portfolios under the Treasurer's</p>

management. (18) From Dr. Ahimsa Sumchai, regarding Mission Bay Helicopter Operations. (19) From Dr. Ahimsa Sumchai, regarding hearing on proposed helipad at UCSF Mission Bay. (20) From Dr. Ahimsa Sumchai, regarding the Lennar Corporation and Candlestick Park. (21) From Dr. Ahimsa Sumchai, submitting support for proposed rooftop helipad at UCSF Mission Campus. Copy: Each Supervisor (22) From Sue Cauthen, submitting the Library Citizens Advisory Committee annual report. (23) From Amanda Egron, concerning the takeover of Access TV by the group known as BAVC. (24) From Department of Public Works, regarding the status of repairing potholes at Fillmore and Golden Gate Avenue. (Reference No. 20090714-005) (25) From Port Commission, submitting the annual contracting activity report for the period of April 1, 2009 through June 30, 2009. (26) From Bay-Delta Sport Fishing Enhancement Stamp Program, submitting request for proposed projects that would benefit sport fish populations, sport fishing opportunities and anglers within the geographic range of Golden Gate Bridge to the most downstream dam of the Sacramento and San Joaquin rivers and their tributaries. (27) From concerned citizens, submitting support for the "Traffic Calming" plan for Market Street. 2 letters (28) From Ivan Pratt, regarding support for the Ryan White Program. (29) From concerned citizens, submitting support for preserving the historic 18-hole Sharp Park Golf Course. 29 letters (30) From concerned citizens, submitting support for restoring Sharp Park to a natural area. 8 letters (31) From Emil Lawrence, regarding the non-stop cancellation of Municipal Transportation Agency (MTA) commission meetings. Copy: Each Supervisor (32) From Robert Edwards, regarding his current living conditions. (33) From Vicki Leidner, submitting opposition to Senate Bill 792. (34) From Francisco Da Costa, regarding "thousands of units being built in the middle of a toxic triangle" in San Francisco. (35) From Francisco Da Costa, regarding the Air Quality Community Dialogue meetings. (36) From Francisco Da Costa, regarding the City and County's proposed budget for FY 2009-2010. (37) From Francisco Da Costa, requesting a hearing on the Ethics Commission and Mayor Gavin Newsom. (38) From Francisco Da Costa, regarding Proposition G. (39) From Joe Krivan, regarding alleged activities by the Police Department. (40) From Andrea O'Leary, regarding the need for park rangers in all city parks. (41) From Francis, requesting a bus shelter is placed at Oakpark Drive and Clarendon Avenue. (42) From Diane Palacio, submitting support for the renaming of Candlestick Park (preferably temporary, time negotiable) for the exclusive purpose of using the proceeds to fund director positions at City parks and playgrounds. File No. 090631, Copy: Budget & Finance Clerk (43) From Elizabeth Riegle, submitting copy of letter sent to the Citation Review Center requesting the dismissal of a parking citation. (44)

Indexes:

Sponsors:

History of Legislative File 090951

Ver	Acting Body	Date	Action	Sent To	Due Date	Pass/Fail
-----	-------------	------	--------	---------	----------	-----------

SOUTHEAST COMMUNITY FACILITY COMMISSION
CITY and COUNTY of SAN FRANCISCO

Willie B. Kennedy
President
Louise C. Jones
Vice President
Bobbrie Brown
Commissioner
Kenneth Sampson
Commissioner
Caesar Churchwell
Commissioner
Karen Chung
Commissioner
Helen Yang
Commissioner

Gavin Newsom, Mayor



Toye Moses,
Executive Director

MEMORANDUM

TO: The San Francisco Board of Supervisors
City and County of San Francisco
City Hall, Room 244
1 Dr. Carlton B. Goodlett Place
San Francisco, CA 94102

THRU: Ms. Angela Cavillo, Clerk of The Board
San Francisco Board of Supervisors
City Hall, Room 244
1 Dr. Carlton B. Goodlett Place
San Francisco, CA 94102

FROM: Toye Moses, Executive Director
Southeast Community Facility Commission

SUBJECT: Submission of the Southeast Community Facility Commission
"Annual Statement of Purpose & Annual Report July 1, 2008 –
July 31, 2009"

DATE: July 13, 2009

BY RC
2009 JUL 15 PM 2:41
RECEIVED
BOARD OF SUPERVISORS
SAN FRANCISCO

As legislatively mandated please find enclosed the Southeast Community Facility Commission "Annual Statement of Purpose and Annual Report for 2008-2009 Fiscal Year".

Respectfully Submitted,

Kenneth Oliver for Dr. Toye Moses

Toye Moses, Executive Director
Southeast Community Facility Commission

TM:cv
7/13



2008-2009 Annual Report
SOUTHEAST COMMUNITY
FACILITY COMMISSION
CITY & COUNTY OF SAN FRANCISCO

1800 Oakdale Avenue, Suite B
San Francisco, California 94124

Telephone: (415) 821-1534

Event Schedule: (415) 821-0921

Facsimile: (415) 821-1627

Website: <http://www.sfgov.org/sefacility>

**SOUTHEAST COMMUNITY
FACILITY COMMISSION**

***ANNUAL STATEMENT OF
PURPOSE***

&

ANNUAL REPORT

JULY 1, 2008 – JUNE 30, 2009

**THE SOUTHEAST COMMUNITY FACILITY COMMISSION
IS PLEASED TO PRESENT THIS ANNUAL STATEMENT
OF PURPOSE AND ANNUAL REPORT TO THE MAYOR,
BOARD OF SUPERVISORS, AND THE CITIZENS OF SAN
FRANCISCO**

SECF COMMISSIONERS:

*Willie B. Kennedy, President
Louise C. Jones, Vice President
Bobbrie Brown
Kenneth J. Sampson
Caesar Churchwell
Karen Chung
Helen Yang*

STAFF

*Toye Moses, Executive Director
Kenneth Olivencia, Mgmt. Assistant
Carla Vaughn, Commission Secretary
Cheryl-Berna' Adams, Clerk Typist*

BACKGROUND HISTORY & ANNUAL STATEMENT OF PURPOSE July 1, 2008 - June 30, 2009

Background History

ORDINANCE SEC. 54.1 of the San Francisco Board of Supervisors established The Southeast Community Facility (SECF) Commission located at 1800 Oakdale Avenue in 1987. The Southeast Community Facility was built as a mitigation measure in return for the Bayview-Hunter's Point (BVHP) community's acceptance of the Southeast Water Treatment Plant in the midst of their neighborhood.

Additionally, in order to obtain approval for the construction of the sewage treatment plant, the City of San Francisco agreed to operate and maintain, at City cost, this facility for the benefit of the Bayview Hunterspoint community. The members of the SECF Commission are appointed and serve at the pleasure of the Mayor.

The Southeast Community Facility (SECF) located at 1800 Oakdale Avenue is a community-based and oriented facility with numerous programs and services. For example, SEC Facility has an educational/training complex leased by the San Francisco Community College District, HeadStart Childcare Programs provided by San Francisco State University. Also, the SEC Facility is leased to non-profit community based organizations (CBO) that provide services to all San Francisco residents. Most of the programs provided are non-profit in status making them affordable to all members of the public. In conjunction with community based organizations, tenants as well as government agencies, we offer a wide range of assistance in the areas of employment opportunities provided by Department of Human Services/One Stop tax preparation, basic needs information, voter registration provided by Community of Opportunities/Single Stop, criminal expungement services provided by the SF Public Defender, and scholarship awards programs. The San Francisco Sunshine Ordinance mandates that public notices be disseminated in time to allow residents an opportunity to attend all functions provided by and at the SEC Facility.

The SEC Facility is centrally located and accessible to members of the public. Many government agencies and community-based organizations have used our facilities (*Alex Pitcher Community Room and E.P.Mills Community Center*) to hold events, training workshops and seminars, job and health fairs, election polls, graduation award ceremonies, and town hall meetings to inform and acquaint San Francisco residents about current events.

STATEMENT OF PURPOSE

The purpose of the SECF Commission is to review and provide guidance regarding the operations of the SEC Facility and the other facilities under its jurisdiction.

The yearly goal of the SECF Commission is to promote and advocate improving the general economic, physical, health, public safety and welfare of all residents of San Francisco, but particularly those in the BVHP Community.

**SOUTHEAST COMMUNITY FACILITY COMMISSION
ANNUAL REPORT
FISCAL YEAR 2008-2009**

HIGHLIGHTS OF THE YEAR

The Southeast Community Facility (SECF) Commission continues to oversee the operation and maintenance of the SEC Facility, the Greenhouses and continues to have an advisory role with respect to significant decisions relating to the use of the Earl P. Mills Community Facility, and the three satellite childcare centers (Whitney Young Childcare Center, Martin Luther King Childcare Center, and Sojourner Truth Childcare Center), including the opportunity to review and provide comments on any and all future leasing activity.

The SECF Commission also continues to advocate for and support BVHP community organizations, health, welfare and economic development activities beneficial to all San Francisco residents, with emphasis on increasing opportunities for those who are disfranchised in the BVHP area.

The fiscal year 2008-2009 has been a year of significant accomplishment for the SECF Commission. As part of Mayor Gavin Newsom's commitment to revitalizing the BVHP neighborhood, the 5th edition of San Francisco Southeast Sector Resource Directory was created. This Resource Directory is currently being widely distributed throughout the City including the Mayor's office, Board of Supervisors, Congresswoman Nancy Pelosi, Senators Mark Leno, Leland Yee, Assemblyman Tom Ammiano, Assemblywoman Fiona Ma, and City agencies, community based organization, and also made available to the general public.

The updated 5th edition of the Southeast Sector Resource Directory is a valuable source for informing San Francisco residents about the wealth of civic, religious, economic and social institutions available in the BVHP neighborhood. In addition to listing the businesses serving the Bayview-Hunter's Point area, we have also included organizations, churches, financial/legal assistance, medical/family support services, educational/training locations, and childcare facilities.

HIGHLIGHTS OF THE YEAR

On July 10, 2008: Akbar Lashanlo, PUC/Resident Engineer presented an update on the Southeast Community Facility Commission ADA project.

On July 23, 2008: Ed Harrington, PUC/General Manager, presented on "SFPUC Issues Affecting the BVHP Community".

Alma Robinson, Esq., Executive Director, California Lawyers for the Arts and Andrea Bruss, Joint Development, Mayor's Office of Economic & Workforce Development presented on the July 31 Community Planning Workshop.

On August 14, 2008: Steven Moss, Founder/Executive Director, San Francisco Community Power, presented on "Saving the Environment, One Community At A Time".

Highlights of the Year (cont.)

September 11, 2008: Dave Pearson, SF State University, Head Start Program at Southeast Community Facility presented an update on Head Start Program activities and Environmental Health Issues.

Dwayne Jones, Director, Communities of Opportunity presented on the Single Stop Program at the Southeast Community Facility.

September 24, 2008: Carlos Garcia, Superintendent of Schools, San Francisco Unified School District presented an update on the status of the BayView Hunter's Point Schools, and specifically the Dream Schools.

Stephen Proud, Lennar Project Manager presented an update on the Alice Griffith Housing Project.

October 9, 2008: Edward Reskin, Director, Department of Public Works presented a general overview of the Department of Public Works.

Dwayne Jones, Director, Communities of Opportunity presented on Hope SF, Gateway to College, and The Rap Project.

January 8, 2009: John Roddy, Esq., Deputy City Attorney presented regarding the SF Administrative Code Chapter 54.1 that created the Southeast Community Facility Commission
Dr. Don Q. Griffin, Chancellor, City College of San Francisco presented a general update on "City College of San Francisco and the Southeast Campus".

February 12, 2009: Mike Farrah, Director, Mayor's Office of Neighborhood Services presented a general update on "Goals, Activities, and how the BayView Hunter's Point residents benefit from the programs offered.

Zane Blaney, Executive Director, ACCESSF Community Media, presented on "Public Access Channels Information/Outreach to the BVHP Neighborhood

February 25, 2009: Michael Gordon, Resident and Ali Wolfe, Supervisor, Delancey Street Foundation, on behalf of Mimi Silbert, Executive Director, presented on "How BayView Hunter's Point Residents Benefit From The Program And The Training Center Located In The Southeast Sector".

March 12, 2009: Simin Shamji, Director, SF Public Defender's Office, Specialty Courts and Re-entry Program, presented an update on the Clean Slate Program Offices Citywide; especially the Southeast Community Facility Commission office.

April 22, 2009: David Chiu, President, San Francisco Board of Supervisors, presented on "Our Common Ground, Issues Affecting BVHP Community, Economic Development, Youth Unemployment, Health, Safety, & The Ability To Stay Afloat During These Tough Financial Times, His Vision & Goals".

Karri Ving, Coordinator, SFPUC/WWE Biofuel Program, presented an update on the San Francisco Grease cycling Program

May 27, 2009: Jed Silver, Project Manager, Business Development, Inc. presented on the Environmental Impact Statement for the BayView Waterfront Project.

June 24, 2009: John Scott, President, John Scott Consulting, Inc. presented an update on the progress of the Parcel A/Phase One construction at the Shipyard.

Policy Management

As legislatively mandated, implemented and enacted, the following are policies and directives adopted by the SECF Commission:

- To handle all logistical arrangements for the SECF Commission and its committee meetings two - three times monthly.
- Implement new security measures after the 911 and recent terrorist incidents by installing an electric gate/intercom system in the Southeast Facility parking lot area. Also installed were new security cameras for the administrative office and the perimeter of parking lot area.
- In conjunction with the Real Estate Department continue to manage the lease agreements for space usage at the four facilities under the "General Fund" budget.
- In conjunction with the PUC/Commercial Land Management Department continue to manage lease agreements for use of space at the Southeast Community Facility and Greenhouse under the "Clean Water Fund" budget. The lease for the Green House that was renewed to Decorative Plant Services is now responsible for all maintenance costs related to the Greenhouse.
- Insure compliance with all relevant City, State and Federal laws and regulations including but not limited to, capital improvement grants, lease/contract agreements and work/service orders.
- To Maintain compliance with regulatory requirements and particularly related to the American Disabilities Act (ADA).

Outreach to Government, Business, Community Organizations and Interested Individuals:

SECF Founder's Mural and Dedication

In November of 2007, a Mural, depicting the founders of the Southeast Community Facility Commission was completed. Local Bayview artist, Santee Huckaby, painted the mural. The dedication ceremony for the mural was also held in November. In attendance were the current SECF Commissioners, and two of the remaining SECF co-founders: Shirley Jones and Espanola Jackson. City Supervisor Sophie Maxwell, Dwayne Jones, and Claude Everhart gave speeches, among others. The Event turned out to be a great success with refreshments for the attendees following the dedication.

ADA-COMPLIANCE UPGRADES

Beginning January, 2008, the PUC began funding a large-scale project to ensure that all entry ways, restrooms, water faucets, ramps and general walkways on the SECF premises are ADA-compliant. PUC workers replaced the roof deck with a water proof deck; replaced all drinking fountains with high and low rise fountains and installed one new outdoor drinking fountain. Interior handrails were modified per life safety requirements and installed in all restrooms. Our landscapes were modified for ADA compliance including retrofit of pavement, ramps, stairways, irrigation systems, trees were added, planting areas, preparation and execution of pedestrian traffic routing plans; new exterior fences were installed for safety and child playground code compliance.

This contract has reached substantial completion.

HVAC upgrades for SECF

The SECF building HVAC systems upgrades are completed. A new absorption chiller with a new style screw type electric chiller was included, and the cooling tower was also replaced.

Lead paint in Snake Sculpture and fences near Headstart Childcare Center.

Lead was discovered in the tiling of the snake sculpture located in the playground area of the Childcare Facility at the SECF. PUC Health and Safety personnel then immediately barricaded the play area with the snake sculpture. It was decided by the SECF Commission that the snake be completely removed for the safety of all, especially the children attending the Childcare Center. Additionally, all of the sand on the play area was carefully removed and replaced. This decision was made with the advice of PUC Health and Safety Officials.

The fences along the rear of the SECF building, next to the Childcare area and parking lot, were also discovered to have lead-contained paint. This fencing was replaced and we are in the process of repainting it with non-lead paint.

Business Development

The SECF Commission is very committed to the economic revitalization of Bayview-Hunter's Point and wants to see Mayor Gavin Newsom's vision of jobs, housing and economic vitality for area residents become a reality. The SECF Commission's continued efforts include written letters of support for businesses, individuals and community organizations seeking support in promoting or bringing business to the BVHP. The SECF Commission has also invited public officials, representatives/entrepreneurs from business enterprises to address and inform/educate the Commission and the community-at-large: Mr. Alton Byrd, Lennar/BVHP who updated the SECF Commission and BVHP Community on the status of Interim Marketplace located at the Bayview Opera House.

The SECF Commission would like to extend personal thanks to the following individuals/organizations for volunteering time, contributing monetary and in-kind donations toward the Southeast Community Facility Founders Mural Project, as well as economic development of the Bayview Hunter's Point area.

Ed Harington, PUC General Manager, Tommy Moala, Assistant General Manager. PUC/WWE, Laura Spanjian, PUC/Assistant general Manager, Tony Flores, Manager/PUC/WWE, Heidi Hardin, Think Round Inc., Dwayne Jones, Director Mayor Office of Community of Opportunities, Supervisor Sophie Maxwell, Dr. Veronica Hunnicutt, Commissioner Linda Richardson, Alma Robinson, Executive Director California Lawyers For the Arts, Messrs. Greg George, Sam Murray/PUC, Jeffrey Betcher/Quesada gardens, John Chung/Associated Builders, Tony Caruso/Decorative Plant Services, Keith Jackson/Home Depot; Mr. Kofi Bonner/ BVHP Lennar; Southeast Community Facility Commissioners, and the host of individuals who have graciously volunteered their time.

Health & Environmental

The SECF Commission's Health and Housing Ad Hoc subcommittee, headed by Commissioner Louise Jones, works on issues related to the health and environment of the community, most especially health issues impacting children and young adults. The Ad-hoc subcommittee organized a health fair in the Alex Pitcher community room of the SECF. The health fair was titled: Healthy Bodies, Healthy Minds, and Families First. The fair targeted the diabetes and obesity issue facing youth in the Bayview-Hunter's Point community. Three Bayview Hunter's Point elementary schools; George Washington Carver, Bret Harte and Drew participated in the health fair by providing assistance in advertising and promoting the event to students and their families. The event was a success with students and families from each of the three schools in attendance. Various community organizations also provided food, nutritional information/giveaways as well as raffle prizes for students, their families and community members as well. With the success of this initial health fair sponsored by the SECF Commission and held at the SECF, it was decided unanimously by the SECF Commissioners that this should become an annual event for the community. Special thanks to all the Health Fair participants, most especially, University of California Medical students coordinated by Willie ford Moses, UCSF Medical School professors, Commissioner Louis C. Jones, Dr. Churchwell, Dr. Parker and PUC/WWE staff

Public Safety

The SECF Commission is aware and concerned about the need for public safety throughout the City, particularly in the Southeast Sector.

In June 2009, the PUC contracted with Applied Video Solutions to begin installing new High Definition video cameras in the Parking lot, loading dock and along the rear of the SECF building/fence line. The High Definition cameras also view the fence line surrounding the parking lot area. These new High Definition cameras will improve the existing security camera surveillance in the rear of the Southeast Community Facility.

FY 2009-2010 Budget

The SECF Commission's FY 2008-2009 budget was \$916,223 of Southeast Community Facility Fund allocation. The SECF Commission would like to increase its budget to hire more staff and to improve the inherent infrastructure problems associated with running the facilities.

Membership and Administration

The SECF Commission has seven members appointed by the Mayor, a staff of three full-time and one clerical assistant. The current Commissioners are: President Willie B. Kennedy, Vice-

President Louise Jones, Caesar Churchwell, Kenneth Sampson, Karen Chung, Bobbie Brown and Helen Yang.

The SECF Commission also has four Sub-committees: **Facilities Committee** chaired by Commissioner Kennedy (Focuses on tenant leases, rules & regulations for rental of Alex Pitcher Community Room and Earl P. Mills Auditorium); **Health, Housing Ad-Hoc Committee** chaired by Commissioner Jones (Focuses on health); **Public Safety & Outreach Ad-Hoc Committee** (Focuses on issues pertaining to the tenants, programs, community outreach, education) and the **Southeast Community Facility Commission Advisory Group, (SECF/CAG)** co-chaired by Dr. Caesar Churchwell and Shirley Jones, former SECF Commission/President. The CAG focuses on the BVHP community issues and concerns.

The FY `08-09 Staff was headed by **Toye Moses**, Executive Director (to the Commission); **Carla Vaughn**, Commission Secretary (handles correspondence and agenda items, attends meetings/transcribes minutes, and performs routine office tasks); **Kenneth Olivencia**, Mgmt. Assistant responsible for coordinating all inter-departmental work/service orders; and **Cheryl Berne' Adams**, Clerical Assistant (coordinates community room rentals/activities, performs routine office tasks, and assists in mailers). Additionally we have two **work-ordered** personnel assigned from the Department of Real Estate (Stationary Engineer Richard O'Neal, and Claudette McLean Custodian).

Through the **Mayor's Youth Employment and Education Program (MYEEP)**, the **Young Community Developers (YCD)**, and the **PUC/Summer Youth Program Project PULL**, the **SECF Commission** has been very fortunate to have talented local high school students assist in the Commission's clerical work and outreach to the community during the summer break.

The Future & In-coming Year

As legislatively mandated, the Commission will continue to:

- **Advocate** for improving the general economic, physical, health, safety and welfare of the residents of the southeast sector while ensuring the safe operation of the SEC Facility, the Greenhouse and the Earl P. Mills Center Auditorium.
- **Maintain** good relations with residents and community groups within the southeast sector, the Mayor's office, Board of Supervisors, government officials most especially Public Utilities Commission, City Attorney, Mayor's office Workforce, Mayor's office of Community of Opportunities, BVHP Project Area Committee, Mayor Shipyard Citizen Advisory Committee, Young Community Developers, and all residents of San Francisco.
- **Encourage** local tenants to take stake in the community by becoming home and property owners, and work with developers to increase the percentage of affordable units for sale in development projects in the BVHP.
- **Work** with potential business and housing developers to ensure maximum community benefit opportunities written into the "owner participation agreements".

- Uphold its partnership with the Mayor's Office of Community Neighborhood, BVHP Police Station and Department of Public Works in promoting clean and safe neighborhoods in San Francisco.
- Maintain agreement with American Red Cross since the SEC Facility is designated to serve as an Emergency Red Cross shelter site in case of an earthquake or natural disaster. In the process of designing/building a food storage bunker to be use for feeding Southeast residents in case of an earthquake.
- Maintain an ongoing communication with MUNI regarding the Third Street Light Rail Project and planning process.
- Continue to manage Alex Pitcher Community Room as well as the E.P. Mills Auditorium at 100 Whitney Young Circle.
- Work in conjunction with the PUC/Land management Division in the management of lease agreement for the SEC Facility and the Greenhouse under the Clean Water Fund Budget.
- Work closely with the PUC, General Manager Ed Harrington and the PUC/Wastewater Enterprise in strengthening communication links with the public most especially the Southeast residents on broader issues of community concern.

Community Partnerships in the Coming Year

The SECF Commission and its staff will continue to foster working relationships with the following local/city agencies and state/federal officials:

The Mayor/Office of the Mayor, Board of Supervisors, PUC/General Manager, Mayor's Office of Community Development, City Attorney's Office, Mayor's Office of Community of Opportunities/Single Stop, Mayor's Office of Workforce, San Francisco Police Department Bayview Station, Real Estate Department, Dept. of Human Services/Southeast One Stop, City College/Southeast Campus, Public Defender Office/Clean Slate Program, Assemblyman Tom Ammiano, Assemblywoman Fiona Ma, Senator Mark Leno's Office, Senator Leland Yee's office, Redevelopment Agency, SF Housing Authority, Parks & Recreation, Department of Public Works, Department of Public Health, MUNI, Mayor's Hunters Point Shipyard Citizen Advisory Committee, US Navy's Restoration Advisory Committee, Congresswoman Nancy Pelosi's Office, Department of Health Services, etc.

Additionally, we will partnership with the following private developers, churches, and community-based organizations:

Young Community Developers, Goodwill Industry, Alanique Consultant Company, Providence Baptist Church, The California Lawyers For the Arts, Southeast Alliance for Environmental Justice, BVHP/Project Area Committee, Third Street Light Rail Advisory Committee, BVHP Foundation, Southeast Community College Campus, Bayview Merchants Association, Tenants/Community Room Users, BVHP Opera House, BVHP Rotary Club, BAYCAT, etc.

In conclusion the SECF Commission will continue to foster its commitment in improving the quality of life for the residents of the Southeast Sector and work vigorously to ensure effectiveness of the "BVHP Employment/Housing and Contracting Policy"

The SECF Commission will also continue to promote diversity, health, safety as well as professional development of its employees

Respectfully submitted,

TOYE MOSES, Executive Director
Southeast Community Facility Commission

Document is available
at the Clerk's Office
Room 244, City Hall

SAN FRANCISCO SOUTHEAST SECTOR

RESOURCE DIRECTORY

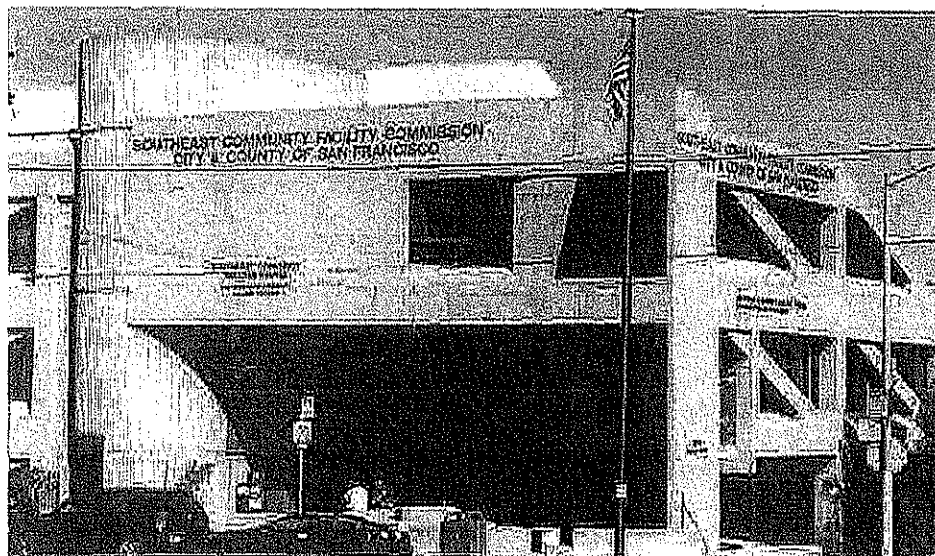

Fifth Edition
January 2009

TOYE MOSES
Executive Director

City & County of San Francisco
SOUTHEAST COMMUNITY FACILITY COMMISSION
1800 Oakdale Avenue • San Francisco, CA 94124
(415) 821-1534 • (Fax) 821-1627 • (E-mail) www.ci.sf.ca.us/scfacility

Document is available
at the Clerk's Office
Room 244, City Hall

AC, GJ
Cpage

RECEIVED
BOARD OF SUPERVISORS
SAN FRANCISCO

2009 JUL 14 PM 12:48

BY rc

**RECOMMENDATIONS OF THE
BUDGET AND FINANCE COMMITTEE
FOR AMENDMENT OF BUDGET ITEMS**

2009-2010

July 2009

2

Document is available
at the Clerk's Office
Room 244, City Hall

BOS-11

RECEIVED
BOARD OF SUPERVISORS
SAN FRANCISCO

2009 JUL 15 AM 9:56

BY

rc



THE OFFICE OF CITIZEN COMPLAINTS

QUARTERLY REPORTS

Second Quarter 2009

Included In This Document

Comprehensive Statistical Report
Comparative Overview of Caseload
How Complaints Were Received
Complaints and Allegations by Unit
Findings In Allegations Closed
Days to Close – All Cases Closed
Days to Close – Sustained Cases
Investigative Hearings and Mediations
Status of OCC Cases – Year 2007
Status of OCC Cases – Year 2008
Caseloads by Investigator
Case Closures by Investigator
Weighted Closures by Investigator
Presented by: Joyce M. Hicks, Executive Director
Compiled by: Chris Wisniewski and Linda Taylor



RECEIVED
BOARD OF SUPERVISORS
SAN FRANCISCO

2009 JUL 15 PM 2:42

BY RC

C:ML
Adult Probation Department
Hall of Justice

PATRICK J. BOYD
Chief Adult Probation Officer

*Protecting the Community, Serving Justice and
Changing Lives*

Date: July 14, 2009
To: Ms. Angela Calvillo, Clerk of the Board
Thru: Patrick J. Boyd, Chief Adult Probation Officer
From: Diane Lim, Chief Financial Officer/Business Manager *DL*
Re: Adult Probation Department Sole Source Contracts for Fiscal Year 2008-09

In compliance with Sunshine Ordinance Section 67.24 (e), the Adult Probation Department is reporting that no sole source contracts existed in the Department prior to Fiscal Year 2008-09.

In Fiscal Year 2008-09 the Adult Probation Department worked with the Office of Contract Administration, the Department of Human Resources, the City Attorney and Local 21, for approval to enter into a sole source contract.

<u>Term</u>	<u>Vendor</u>	<u>Amount</u>
November 2008-October 2011	National Council on Crime and Delinquency	\$102,000

Reason

The Correctional Assessment and Intervention System ("CAIS") is an interactive web-based subscription that analyzes information provided by the Deputy Probation Officer regarding an adult offender to determine case management classification, create risk and needs assessments, and provide specific recommendations regarding the supervision of the offender. As part of its recommendations for supervision, CAIS identifies the specific strategies that research shows will most likely result in positive change for the offender. The scoring and analysis of the data is provided via a conventional web browser in a series of concise, interactive reports. The CAIS subscription also includes a web-based data reporting package which produces aggregate reports based on data provided. These reports can be generated at any time at the subscriber's discretion.

CAIS is used throughout San Francisco's Adult Probation Department ("APD"). All departmental Probation Officers use CAIS as a case assessment tool for all existing and new cases. The system maintains data regarding offender counts, demographics, and other information, and analyzes the data to make important determinations such as offender type and risk level, and to generate automated profiles of APD's client base, which are critical for strategic planning purposes and prioritization of staffing levels and supervision requirements.

Should you have any questions please contact me at 553-1058

4



Julian Low/MAYOR/SFGOV

07/14/2009 09:16 AM

To Board of Supervisors/BOS/SFGOV@SFGOV

cc

bcc

Subject Re: Fw: Reminder: Sole Source Contracts and Annual Reports

The Mayor's Office did not enter into any sole source contracts during the fiscal year 2008-2009.

Julian Low
Director of Operations
Mayor's Office

Board of Supervisors

As of this date, the Clerk of the Board has not..

07/13/2009 06:26:57 PM

From: Board of Supervisors/BOS/SFGOV
 To: Patrick Boyd/ADPROB/SFGOV@SFGOV, Luis Cancel/ARTSCOM/SFGOV@SFGOV, jxu@asianart.org, Phil Ting/ASRREC/SFGOV@SFGOV, Vivian Day/DBI/SFGOV@SFGOV, Edwin Lee/ADMSVC/SFGOV@SFGOV, Tara Collins/CTYATT@CTYATT, Ben Rosenfield/CON/SFGOV@SFGOV, District Attorney/DA/SFGOV@SFGOV, Michael Cohen/MAYOR/SFGOV@SFGOV, John Arntz/ELECTIONS/SFGOV@SFGOV, Vicki Hennessy/OES/ECDEPT/SFGOV@SFGOV, jbuchanan@famsf.org, Joanne Hayes-White/SFFD/SFGOV@SFGOV, Bart Duncan/HSS/SFGOV@SFGOV, Micki Callahan/DHR/SFGOV@SFGOV, Chris Iglesias/HRC/SFGOV@SFGOV, Trent Rhorer/DHS/CCSF@CCSF, Julian Low/MAYOR/SFGOV@SFGOV, Nathaniel.Ford@sfmta.com, John Rahaim/CTYPLN/SFGOV@SFGOV, Monique Moyer/SFPORT/SFGOV@SFGOV, Jeff Adachi/PUBDEF/SFGOV@SFGOV, Mitch Katz/DPH/SFGOV@SFGOV, lherrera@sfpl.info, EHarrington@sfgwater.org, Ed.Reiskin@sfdpw.org, Margaret McArthur/RPD/SFGOV@SFGOV, Eileen Hirst/SFSD/SFGOV@SFGOV, Elizabeth Murray/WMPAC/SFGOV@SFGOV
 Date: 07/13/2009 06:26 PM
 Subject: Fw: Reminder: Sole Source Contracts and Annual Reports

As of this date, the Clerk of the Board has not received your department's response regarding Sole Source Contracts as requested in the email below. Responses were due by July 10.

Note: If you do not have any sole source contracts to report, a response is required to that effect (as requested in the attached memo).

Please respond by July 24. The Clerk of the Board must submit a report to the Board of Supervisors indicating responses received (or not) from departments. The report will be submitted on July 27.

Thank you.

Complete a Board of Supervisors Customer Satisfaction form by clicking the link below.
http://www.sfgov.org/site/bdsupvrs_form.asp?id=18548

----- Forwarded by Board of Supervisors/BOS/SFGOV on 07/13/2009 05:00 PM -----

Board of Supervisors/BOS/SFGOV

To Department Heads/Sole Source

cc

06/05/2009 07:16 PM

Subject Reminder: Sole Source Contracts and Annual Reports

Brent Lewis/DHR/SFGOV

07/14/2009 10:30 AM

To Board of Supervisors/BOS/SFGOV@SFGOV

cc

bcc

Subject Reminder: Sole Source Contracts and Annual Reports

The Department of Human Resources did not enter into any sole source contracts during the past fiscal year - FY 2008-09.

Thanks,
Brent Lewis
Budget & Finance Director
Dept. of Human Resources
415-557-4944

Board of Supervisors

----- Original Message -----

From: Board of Supervisors
Sent: 07/13/2009 06:26 PM PDT
To: Patrick Boyd; Luis Cancel; jxu@asianart.org; Phil Ting; Vivian Day; Edwin Lee; Tara Collins; Ben Rosenfield; District Attorney; Michael Cohen; John Arntz; Vicki Hennessy; jbuchanan@famsf.org; Joanne Hayes-White; Bart Duncan; Micki Callahan; Chris Iglesias; Trent Rhorer; Julian Low; Nathaniel Ford; John Rahaim; Monique Moyer; Jeff Adachi; Mitch Katz; lherrera@sfpl.info; Ed Harrington; Ed Reiskin; Margaret McArthur; Eileen Hirst; Elizabeth Murray
Subject: Fw: Reminder: Sole Source Contracts and Annual Reports

As of this date, the Clerk of the Board has not received your department's response regarding Sole Source Contracts as requested in the email below. Responses were due by July 10.

Note: If you do not have any sole source contracts to report, a response is required to that effect (as requested in the attached memo).

Please respond by July 24. The Clerk of the Board must submit a report to the Board of Supervisors indicating responses received (or not) from departments. The report will be submitted on July 27.

Thank you.

Complete a Board of Supervisors Customer Satisfaction form by clicking the link below.
http://www.sfgov.org/site/bdsupvrs_form.asp?id=18548

----- Forwarded by Board of Supervisors/BOS/SFGOV on 07/13/2009 05:00 PM -----

**Board of
Supervisors/BOS/S
FGOV**

To Department Heads/Sole Source

cc

06/05/2009 07:16
PM

Subject Reminder: Sole Source Contracts and Annual Reports



Mark McLoughlin
<MMcLoughlin@asianart.org>
>

07/14/2009 08:23 AM

To Jay Xu <JXu@asianart.org>,
Board.of.Supervisors@sfgov.org
cc Valerie Pechenik <vpechenik@asianart.org>
bcc

Subject Re: Fw: Reminder: Sole Source Contracts and Annual Reports

The Asian has no sole source contracts.

Under Charter Section 5.101, the War Memorial and performing Arts Center, Asian Art Museum and Fine Arts Museums have broad management and contracting powers. As "Charitable trust" departments they "have exclusive charge of the trusts and all other assets under their jurisdiction" and "have authority to maintain, operate, manage, repair or reconstruct existing building and construct new buildings and to make and enter into the budgetary and fiscal provisions of this Charter."

Thanks,

Mark McLoughlin
Chief Operating Officer & CFO
Asian Art Museum of San Francisco
200 Larkin Street
San Francisco, CA 94102
415.581.3730
www.asianart.org

Jay Xu/AAM

07/13/2009 07:51
PM

To Valerie Pechenik/AAM@AAM, Mark
McLoughlin/AAM@AAM

To

cc

Subject

Fw: Reminder: Sole Source
Contracts and Annual Reports

Can you take care of it?

Jay Xu,
Director
Asian Art Museum of San Francisco
Chong-Moon Lee Center for Asian Art and Culture
200 Larkin Street
San Francisco, CA 94102
Tel: (415) 581-3750
Fax: (415) 861-2382

City and County of San Francisco

Department of Public Health

Office of Contract Management and Compliance



MEMORANDUM

Date: July 14, 2009

To: Angela Calvillo
 Clerk of the Board
 Board of Supervisors

From: Gregg Sass 
 Chief Financial Officer
 Department of Public Health

Re: Sole Source Contracts for Fiscal Year 2008-09

RECEIVED
 BOARD OF SUPERVISORS
 SAN FRANCISCO
 2009 JUL 16 PM 3:38
 BY 

Please find enclosed our annual list of sole source contracts entered into during the 2008/09 fiscal year.

If you have any questions on this report, please contact me or Jacquie Hale, Director of our Office of Contract Management and Compliance (554-2609).

Thank you.

cc: Anne Okubo

Start Date	End Date	Vendor Name	Amount	Service Type
S.F. Administrative Code Chapter 21.5(b): Other Purchases, Commodities or services available only from a sole source				
<i>Medical and Related Services:</i>				
7/1/2007	6/30/2012	Autotransfusion	\$ 250,000	Proprietary autotransfusion equipment, and the Autotransfusionists
1/1/2009	12/31/2012	Blood Centers of the Pacific	\$ 9,950,000	Blood and related blood products for San Francisco General Hospital
7/1/2006	6/30/2011	Compumed	\$ 47,999	ECG machines and ongoing ECG interpretations
1/1/2009	12/31/2013	SearchAmerica	\$ 1,103,323	Credit validation services through proprietary database for the patient financial services group at the Community Health Network
4/1/2009	12/31/2009	Stop AIDS Project	\$ 83,748	Assessing internet users preferences for structural and network interventions
7/1/2006	6/30/2010	Support for Families of Children with Disabilities	\$ 623,110	Liaison services and support for coordinated care for Children with Special Health Care Needs
1/1/2007	12/31/2010	University of Pittsburgh	\$ 285,000	Expert participation in project review team for the Behavioral and Social Consequences of HIV/AIDS (BSCH) Study
<i>Regents of the University of California (UCSF):</i>				
3/1/2008	6/30/2011	UCSF AIDS Health Project	\$ 537,600	HIV health services
3/1/2008	6/30/2011	UCSF AIDS Health Project	\$ 10,758,000	Mental health services
1/1/2007	12/31/2009	Regents of the University of California	\$ 4,500,000	TB Ward at San Francisco General Hospital
7/1/2008	6/30/2009	Regents of the University of California	\$ 293,046	Prevocational and vocational opportunities
3/1/2009	6/30/2013	Regents of the University of California	\$ 225,000	HIV Return to Work legal services
1/1/2003	12/31/2009	Regents of the University of California	\$ 55,000	Prenatal and neonatal training programs
7/1/2007	12/31/2008	Regents of the University of California	\$ 2,414,281	On-site medical and psychiatric services related to methadone dosing at San Francisco General Hospital
7/1/2007	12/31/2009	Regents of the University of California	\$ 770,834	Crisis intervention and psychiatric assessment and San Francisco General Hospital
<i>Immunization and Related Services:</i>				
7/1/2006	6/30/2009	Chinese Hospital-Excelsior Health Services	\$ 45,000	Immunization and tracking services for infants and toddlers in Asian communities
7/1/2006	6/30/2009	Mission Neighborhood Health Center	\$ 135,000	Education and routine preventive health services related to immunizations for parents and children in the Mission District
7/1/2006	6/30/2009	North East Medical Services	\$ 120,000	Immunization and tracking services to pediatric patients
7/1/2006	6/30/2009	Regents of the University of California	\$ 30,000	Immunization of toddlers and children
7/1/2008	6/30/2011	San Francisco Study Center	\$ 284,028	Services in support of the immunization program
<i>Healthy San Francisco:</i>				
7/1/2008	6/30/2009	San Francisco Community Health Authority	\$ 5,900,000	Administrative services for Healthy San Francisco
7/1/2008	6/30/2009	San Francisco Community Health Authority	\$ 9,000,000	Services of non-DPH agencies for Healthy San Francisco
6/1/2007	6/30/2012	The Center to Promote Healthcare Access	\$ 1,828,341	One-e-App, the web-based eligibility screening and determination system for Healthy San Francisco
<i>Children's Mental Health Services:</i>				
5/1/2008	12/31/2009	A Better Way, Inc.	\$ 2,200,800	Outpatient therapeutic visitation services for abused or neglected children and their families
7/1/2007	6/30/2011	Alternative Family Services	\$ 4,452,000	Outpatient therapeutic visitation services for abused or neglected children and their families
<i>Out-of-County Mental Health Services:</i>				
1/1/2006	12/31/2009	Alta Bates/Summit Medical Center	\$ 179,000	Mental health inpatient out-of-county hospital services as-needed
1/1/2006	12/31/2009	BHC Fremont Hospital	\$ 268,800	Mental health inpatient out-of-county hospital services as-needed
1/1/2006	12/31/2009	Mt. Diablo Medical Pavilion	\$ 291,200	As-needed, backup inpatient (emergency 5150 placements) mental health services at out-of-county hospitals
1/1/2006	12/31/2009	Sierra Vista Regional Medical Center	\$ 240,000	As-needed, backup inpatient (emergency 5150 placements) mental health services at out-of-county hospitals
1/1/2006	12/31/2009	Stanislaus County Dept. of Mental Health	\$ 40,000	As-needed, backup inpatient (emergency 5150 placements) mental health services at out-of-county hospitals
7/1/2008	12/31/2008	ValueOptions	\$ 100,000	Outpatient mental health services for children in San Francisco's foster care system who have been placed out-of-county
<i>Substance Abuse Treatment:</i>				
10/1/2007	12/31/2008	Fort Help LLC	\$ 190,000	Methadone treatment and counseling
7/1/2006	12/31/2012	Harm Reduction Coalition	\$ 473,460	Drug Overdose Prevention and Education (DOPE) Project
7/1/2007	6/30/2009	San Francisco AIDS Foundation	\$ 986,644	Substance abuse services for men having sex with men (MSM) who use drugs and/or alcohol, primarily methamphetamine.
<i>San Francisco Mental Health Board:</i>				
7/1/2007	6/30/2011	San Francisco Mental Health and Education Fund	\$ 1,054,914	To provide staff support for the san francisco mental health board

Start Date	End Date	Vendor Name	Amount	Service Type
S.F. Administrative Code Chapter 21.5(b): Other Purchases, Commodities or services available only from a sole source (cont.)				
<i>Housing and Urban Health:</i>				
1/1/2008	6/30/2009	Chinatown Community Development Center	\$ 40,000	Supportive housing for unaccompanied, low-income, severely mentally ill seniors covered by the California Mental Health Services Act (MHSA)
11/1/2005	6/30/2014	Plaza Apartments Associations LP	\$ 5,998,314	Rental subsidies to secure supportive housing units in the newly constructed Plaza Hotel Plaza Apartments, for homeless clients of the Departments Direct Access to Housing (DAH) program
<i>State of California:</i>				
1/1/2009	12/31/2009	Health Management Associates	\$ 65,000	Services and support to finalize concept papers and plans for the California Department of Health Care Services to use to develop any waiver, or amendments to the Medi-Cal state plan necessary for the development and implementation of a program to provide a community-living support benefit to eligible Medi-Cal beneficiaries in San Francisco, pursuant to AB 2968
1/1/2008	6/30/2009	State of California Dept. of Health Services	\$ 295,680	Implementation and monitoring of the AB 2968 pilot project to provide a community-living support benefit to eligible Medi-Cal beneficiaries in San Francisco
11/1/2007	12/31/2011	San Francisco Superior Court	\$ 1,713,600	Court monitoring and supervision for defendants who are potentially eligible for substance abuse treatment services funded by the Substance Abuse and Crime Prevention Act of 2000 (SACPA) ("Prop. 36")
S.F. Administrative Code Chapter 21.30: Software Licenses, Support, Escrow, Finance, and Equipment Maintenance Agreements				
7/1/2008	12/31/2013	BAT Technologies	\$ 30,000	license and maint. for LabBillSys system at the Public Health Lab
1/1/2009	12/31/2009	Common Cents Systems	\$ 30,000	maint. agreement for MLABEE system in the Public Health Lab
7/1/2008	6/30/2009	Dataway	\$ 1,034,524	Management, monitoring consultation on the security infrastructure of DPH's integrated enterprise network system
1/1/2009	12/31/2013	Delta Health Technologies LLC	\$ 522,710	Software maintenance, support, and remote server management for applications used by Health At Home field staff to remotely access patient information, billing, and reporting at the point of care, at clients' homes
7/1/2007	6/30/2009	Echo Consulting Services of California	\$ 974,786	Software support for Community Behavioral Health billing and and patient information system
12/1/2008	12/31/2012	EMS Systems LLC	\$ 122,396	Software maintenance and support the EM Resource Electronic Inventory and Resource Management System for the DPH Emergency Medical Services Agency, the local administrator for San Francisco's hospitals, clinics, ambulances and other emergency responders
7/1/2008	6/30/2009	Genisys Decision Corp.	\$ 48,000	Software maintenance for the Community Health Network budget office
7/1/2008	6/30/2011	InfoMC	\$ 932,541	Software maintenance for Community Behavioral Health Services
7/1/2008	6/30/2011	Legacy Systems Solutions	\$ 180,000	Software maintenance for Jail Health Services
9/1/2005	12/31/2008	M/MGMT Systems	\$ 131,011	Software upgrade to the lab system in use at the Public Health Lab
	6/30/2012	McKesson	\$ 1,953,161	Software license and maintenance for the Pathways Material Management System
4/1/2008	6/30/2011	Morrisey Associates	\$ 165,000	Software licenses, maintenance and support services to upgrade the current Medical Staff Offices application used to credential physicians at San Francisco General Hospital, Laguna Honda Hospital, Community Behavioral Health and the Community Oriented Primary Care centers
8/1/2008	7/31/2010	Performance Logic	\$ 72,800	Additional user licenses, technical support, and training to access Health Commander, a proprietary web-based application, for the San Francisco General Hospital Quality Management Unit
1/1/2009	12/31/2014	Philips Healthcare	\$ 318,300	Software support and maintenance for the critical care system installed in the Intensive Care Unit and Coronary Care Unit at San Francisco General Hospital for the documentation of vital signs and nursing care
1/1/2009	12/31/2014	Philips Healthcare	\$ 441,700	Software licensing and technical service support to upgrade the CareVue Chart critical care system
7/1/2005	6/30/2010	Quadramed	\$ 507,026	Software upgrade for the Quantum Medical Records System
7/1/2006	6/30/2009	RTZ Associates	\$ 1,037,200	Upgrade and related support services for a proprietary web-based application to assist in long-term care placements
7/1/2007	6/30/2012	Siemens Medical Solutions USA	\$ 8,768,815	Products and professional services contract
7/1/2007	6/30/2012	Siemens Medical Solutions USA	\$ 9,858,327	Remote Computing Option

Start Date	End Date	Vendor Name	Amount	Service Type
S.F. Administrative Code Chapter 21.42: Professional Services Contracts for Health and Behavioral Health Services and Support				
1/1/2010	12/31/2010	A Better Way, Inc.	\$ 1,760,640	Outpatient therapeutic visitation services for abused or neglected children and their families
3/1/2007	2/28/2010	AIDS Community Research Consortium	\$ 295,905	Client advocacy and treatment adherence for People of Color
3/1/2007	6/30/2010	AIDS Emergency Fund	\$ 2,144,805	Emergency assistance grants
3/1/2007	6/30/2010	AIDS Emergency Fund	\$ 2,862,292	Emergency assistance grants
3/1/2009	6/30/2013	AIDS Emergency Fund	\$ 3,500,000	Emergency assistance grants
3/1/2007	6/30/2010	AIDS Legal Referral Panel	\$ 739,533	Legal assistance for persons with HIV
3/1/2007	6/30/2010	Ark of Refuge	\$ 905,292	Restoration House
7/1/2007	6/30/2010	Asian Pacific Islander Wellness Center	\$ 675,000	Integrated Case Management for persons with HIV
7/1/2007	6/30/2011	Asian Pacific Islander Wellness Center	\$ 2,580,000	TRANS program
3/1/2008	6/30/2011	Asian Pacific Islander Wellness Center	\$ 336,000	Outreach and case management - San Mateo County
7/1/2008	6/30/2009	Asian Women's Shelter	\$ 43,219	Preventive services, assessment, parent activities, and direct mental health services to young children and their families
11/1/2008	6/30/2010	Asthma Resource Center of San Francisco	\$ 30,000	Services in support of the Asthma Task Force
3/1/2007	6/30/2010	Baker Places	\$ 3,750,786	Ferguson Place, Supportive living and residential subsidies
3/1/2009	6/30/2011	Baker Places	\$ 4,175,409	Ferguson Place, Supportive living and residential subsidies
3/1/2007	6/30/2010	Baker Places	\$ 505,413	HIV Detox Services
7/1/2007	6/30/2010	Baker Places	\$ 2,016,000	Integrated Services Network support services
3/1/2007	6/30/2010	Baker Places	\$ 1,721,085	Star Carmeliot Hotel
7/1/2007	6/30/2010	Black Coalition On AIDS	\$ 1,055,991	Support services for the Empress Hotel
3/1/2007	6/30/2010	Black Coalition On AIDS	\$ 1,143,330	Rafiki and Brandy Moore
7/1/2008	6/30/2009	Boys and Girls Club of San Francisco	\$ 47,342	Mental health and substance abuse services for youth
7/1/2009	6/30/2011	Boys and Girls Club of San Francisco	\$ 94,684	Mental health and substance abuse services for youth
7/1/2007	6/30/2010	Caduceus Outreach Services	\$ 1,551,479	Psychiatric services linked to housing
5/1/2008	12/31/2010	California Family Health Council	\$ 33,600	Chlamydia infertility prevention services
3/1/2007	6/30/2010	Catholic Charities CYO	\$ 1,392,516	Derek Silva Community
3/1/2007	6/30/2010	Catholic Charities CYO	\$ 2,233,698	Assisted Housing
3/1/2008	6/30/2011	Catholic Charities CYO	\$ 504,000	Attendant Care - Leland House and Peter Claver
7/1/2008	6/30/2011	Catholic Charities CYO	\$ 336,229	Rita da Cascia housing services
7/1/2009	6/30/2011	Catholic Charities CYO	\$ 491,731	Assisted Housing
7/1/2009	6/30/2011	Catholic Charities CYO	\$ 992,136	Peter Claver Community
7/1/2006	12/31/2007	Catholic Health Care West-St. Mary's	\$ 686,296	Integrated HIV Services
7/1/2007	6/30/2010	Catholic Health Care West-St. Mary's	\$ 1,350,000	Integrated Case Management and primary care services for persons with HIV
3/1/2009	6/30/2013	Catholic Health Care West-St. Mary's	\$ 2,200,000	Primary Care Services
7/1/2009	6/30/2011	Center for Human Development	\$ 333,151	Substance abuse primary prevention services
7/1/2009	6/30/2011	Center on Juvenile and Criminal Justice	\$ 644,688	Bay Area Services Network and Early and Periodic Screening, Diagnosis and Treatment (EPSDT) services
7/1/2009	6/30/2011	Central City Hospitality House	\$ 2,309,052	Mental health peer-based services
7/1/2009	6/30/2011	Central City Hospitality House	\$ 2,933,168	Mental health socialization, wellness, and housing
7/1/2008	8/31/2011	Chinatown Community Development Corp.	\$ 179,424	Direct Access to Housing for chronic alcoholics at the William Penn Hotel
7/1/2009	6/30/2011	Chinatown Community Development Corp.	\$ 52,954	Supportive Housing at Cambridge Hotel
7/1/2009	6/30/2011	Chinatown Community Development Corp.	\$ 1,158,555	SRO Collaborative in Chinatown and SRO Families United
3/1/2008	6/30/2011	Community Awareness and Treatment Services	\$ 750,000	Residential mental health services for women
7/1/2008	8/31/2011	Community Awareness and Treatment Services	\$ 210,034	Direct Access to Housing for chronic alcoholics at Eddy Street Apts.
7/1/2009	6/30/2011	Community Youth Center of San Francisco	\$ 500,864	Adoption and tailoring of a MultiSystemic Therapy (MST) program
3/1/2007	6/30/2010	Dolores Street	\$ 585,722	Richard Cohen - Nurse Case Management Services
7/1/2009	6/30/2015	Eldergivers	\$ 160,800	Art program for residents of Laguna Honda Hospital
7/1/2007	6/30/2010	Episcopal Community Services of San Francisco	\$ 20,160	Lunch program
7/1/2007	6/30/2010	Episcopal Community Services of San Francisco	\$ 4,291,143	Support services for the homeless at the Pacific Bay Inn, LeNain Hotel, Canon Kip and Rose Hotel
7/1/2009	6/30/2011	Episcopal Community Services of San Francisco	\$ 1,304,822	Substance abuse and mental health services
7/1/2009	6/30/2011	Families First	\$ 572,723	Mental health Day Rehabilitative and Treatment services
7/1/2009	6/30/2011	Fred Finch Youth Center	\$ 308,016	Adolescent Services

Start Date	End Date	Vendor Name	Amount	Service Type
S.F. Administrative Code Chapter 21.42: Professional Services Contracts for Health and Behavioral Health Services and Support				
7/1/2009	6/30/2011	Friendship House Assn. of American Indians	\$ 915,640	Substance abuse treatment services
3/1/2007	12/31/2010	Glide Foundation	\$ 426,255	HIV Counseling, Testing and Linkages (CTL) services
3/1/2007	6/30/2010	Glide Foundation	\$ 436,743	HIV Counseling, Testing and Linkages (CTL) services
7/1/2006	12/31/2010	Haight Ashbury Free Clinics	\$ 271,333	Primary healthcare services to individuals living in San Francisco who are low income or who have no income
7/1/2008	6/30/2009	Haight Ashbury Free Clinics	\$ 3,812,176	Jail Psychiatric Services
7/1/2008	6/30/2009	Haight Ashbury Free Clinics	\$ 3,812,176	Psychiatric Services in the County Jail
7/1/2009	6/30/2011	Hearing and Speech Center of Northern California	\$ 49,900	Audiology services for Laguna Honda Hospital residents
7/1/2009	6/30/2011	Homeless Prenatal Program	\$ 295,617	Substance abuse and mental health services for homeless pregnant women
7/1/2009	6/30/2011	Huckleberry Youth Programs	\$ 360,416	Mental health and substance abuse services
3/1/2008	6/30/2011	Immune Enhancement Project	\$ 900,000	Complementary therapy services
3/1/2010	6/30/2014	Instituto Familiar de la Raza	\$ 575,000	Outpatient mental health services
7/1/2008	6/30/2009	Iris Center	\$ 1,382,366	Counseling, recovery services to uninsured, low-income, dually dx, pregnant/postpartum/parenting women and their children
7/1/2009	6/30/2011	Japanese Community Youth Council	\$ 1,691,023	Asian Youth Prevention Services
7/1/2009	6/30/2011	Jewish Family and Children's Services	\$ 713,025	Mental health services
7/1/2009	6/30/2011	La Casa De Las Madres	\$ 89,554	Mental health and substance abuse services for survivors of domestic violence
7/1/2009	6/30/2011	Larkin Street Youth Services	\$ 367,366	Youth services
7/1/2009	6/30/2011	Larkin Street Youth Services	\$ 2,329,279	Housing, peer-based services
1/1/2010	12/31/2011	Larkin Street Youth Services	\$ 1,797,402	Comprehensive housing and attendant care
3/1/2007	6/30/2010	Latino Commission	\$ 974,188	Residential substance abuse services
3/1/2008	6/30/2011	Latino Commission	\$ 850,000	Residential substance abuse services
7/1/2008	6/30/2009	Learning Services of Northern California	\$ 22,556	Mental health consultation and direct services to SFUSD Child Development Center sites
7/1/2009	6/30/2011	Lincoln Child Center	\$ 187,750	Mental health day treatment intensive, mediation support and residential services
3/1/2007	6/30/2010	Lutheran Social Services	\$ 41,964	Franciscan Towers housing
3/1/2007	6/30/2010	Lutheran Social Services	\$ 358,119	Hazel Betsey housing
7/1/2007	6/30/2010	Lutheran Social Services	\$ 883,623	Support services and rental subsidies at Folsom Dore
3/1/2008	6/30/2011	Lutheran Social Services	\$ 1,700,000	Financial services and assistance for people with HIV/AIDS
5/1/2008	6/30/2009	Lutheran Social Services	\$ 323,875	Housing at 990 Polk Street and at 18th and Alabama Streets facilities
5/1/2008	6/30/2009	Lutheran Social Services	\$ 802,406	La Casa Mariposa - transitional housing for women with children
7/1/2008	6/30/2012	Lutheran Social Services	\$ 1,528,603	Third party rent payment and money management
7/1/2009	6/30/2011	Lutheran Social Services	\$ 588,840	Mosaica and Polk supportive housing
3/1/2011	6/30/2014	Lutheran Social Services	\$ 1,200,000	Money management and financial services for people with HIV/AIDS
7/1/2006	12/31/2010	Lyon-Martin Women's Health Center	\$ 379,184	Primary healthcare to uninsured and underinsured lesbian, bisexual and transgender people
3/1/2008	6/30/2011	Maitri AIDS Hospice	\$ 4,201,500	Residential nursing services
7/1/2009	6/30/2011	Mission Council on Alcohol Abuse	\$ 254,615	Substance abuse services
7/1/2007	6/30/2010	Mission Creek Senior Housing	\$ 1,350,989	Residential subsidies at Mission Creek Senior Community
7/1/2006	6/30/2009	Mission Neighborhood Health Center	\$ 840,000	HIV outreach, testing, and referral services
7/1/2007	6/30/2010	Mission Neighborhood Health Center	\$ 600,000	Integrated Case Management services, including case management, peer and treatment advocacy to persons with HIV
7/1/2007	6/30/2010	Mission Neighborhood Health Center	\$ 750,000	Integrated Case Management services, including case management, peer and treatment advocacy to persons with HIV
3/1/2009	6/30/2013	Mission Neighborhood Health Center	\$ 2,500,000	HIV Centers of Excellence, a comprehensive collaboration of HIV primary care and supportive care service providers
1/1/2010	12/31/2010	Mission Neighborhood Health Center	\$ 339,000	Primary health care and prevention services
7/1/2010	6/30/2013	Mission Neighborhood Health Center	\$ 2,016,000	HIV Early Intervention services
7/1/2009	6/30/2011	Morrissania West	\$ 450,834	Therapeutic counseling and supporting services
7/1/2009	6/30/2011	Mt. St. Joseph's-St. Elizabeth's	\$ 1,871,372	Outpatient substance abuse and mental health services for families in recovery (adults and children)
7/1/2009	6/30/2011	National Council on Alcoholism	\$ 553,563	Substance abuse services for adults
3/1/2009	6/30/2013	Native American Health Center	\$ 680,000	HIV Health Services - Centers of Excellence
3/1/2009	6/30/2013	Native American Health Center	\$ 680,000	HIV Centers of Excellence, a comprehensive collaboration of HIV primary care and supportive care service providers
3/1/2010	6/30/2014	New Leaf	\$ 738,000	Outpatient mental health services
7/1/2009	6/30/2010	NICOS Chinese Health Coalition	\$ 73,920	Gambling prevention and treatment for the Chinese community
7/1/2006	12/31/2010	No. of Mkr. Sr. Svcs. dba Curry Senior Center	\$ 1,613,965	Comprehensive, integrated primary health care to older adults
7/1/2009	6/30/2011	No. of Mkr. Sr. Svcs. dba Curry Senior Center	\$ 1,568,000	Outpatient substance abuse treatment services, mental health services, case management, supportive housing and outreach services for older adults
7/1/2007	6/30/2010	North South of Market Adult Day Health	\$ 1,261,758	Adult day and tenant supportive housing at Mission Creek

Start Date	End Date	Vendor Name	Amount	Service Type
S.F. Administrative Code Chapter 21.42: Professional Services Contracts for Health and Behavioral Health Services and Support				
7/1/2009	6/30/2011	Oakes Children's Center	\$ 165,747	Mental health and substance abuse services
7/1/2008	6/30/2010	Pacific Institute	\$ 376,320	Renovation support at Citizens' Housing Awakenings Project
7/1/2009	6/30/2011	Positive Directions Equals Change	\$ 1,440,452	Outpatient substance abuse services
3/1/2007	6/30/2010	Positive Health Center	\$ 988,960	Benefits counseling services
1/1/2007	6/30/2009	Positive Resource Center	\$ 420,000	Benefits counseling services
3/1/2009	6/30/2013	Positive Resource Center	\$ 270,000	HIV Return to Work legal services
3/1/2010	6/30/2013	Project Open Hand	\$ 4,142,177	Delivered meals/grocery center
1/1/2009	12/31/2012	Public Health Foundation Enterprises	\$ 4,032,000	Food services for persons with HIV/AIDS
1/1/2009	12/31/2011	Public Health Foundation Enterprises	\$ 2,400,000	Support for STD Prevention and Control Programs
1/1/2009	5/31/2014	Public Health Foundation Enterprises	\$ 2,400,000	to provide FI services for STD
9/30/2009	9/29/2013	Public Health Foundation Enterprises	\$ 6,000,000	Support for HIV Prevention programs
7/1/2009	6/30/2011	Rebekah Children's Services	\$ 450,000	Support for HIV Research projects
7/1/2008	6/30/2010	Regents of the University of California	\$ 59,669	Inpatient mental health services
7/1/2009	6/30/2011	Richmond Area Multi-Services	\$ 293,046	Pre-vocational and vocational opportunities for people with severe and persistent mental illness
7/1/2009	6/30/2011	SAGE Project	\$ 3,588,293	Personally Assisted Employment Services (PAES) and SSI Advocacy Support
3/1/2007	6/30/2010	San Francisco AIDS Foundation	\$ 1,141,181	Mental health and substance abuse services for transgender individuals
7/1/2007	12/31/2009	San Francisco AIDS Foundation	\$ 9,991,050	Rental subsidies
3/1/2009	6/30/2012	San Francisco AIDS Foundation	\$ 308,757	STD evaluation, screening, diagnosis, and treatment for Men Who Have Sex With Men attending the Magnet Clinic
7/1/2009	6/30/2012	San Francisco AIDS Foundation	\$ 800,000	Client advocacy, benefits counseling, outpatient mental health services and practical support services collaboration
9/30/2009	9/29/2013	San Francisco AIDS Foundation	\$ 1,325,567	Client advocacy and benefits counseling services for people with HIV/AIDS
7/1/2009	6/30/2011	San Francisco AIDS Foundation	\$ 85,000	HIV Research - Planning and confidential testing
3/1/2008	6/30/2011	San Francisco Food Bank	\$ 279,222	Mental health services
7/1/2007	6/30/2010	San Francisco Fdn. Community Initiative Funds	\$ 338,000	Food solicitation, distribution and liquid supplements
7/1/2007	6/30/2010	San Francisco Network Ministries Housing Corp.	\$ 268,800	Planning, advocacy for food security and sustainable food systems
7/1/2007	6/30/2010	San Francisco Network Ministries Housing Corp.	\$ 195,347	Safehouse for women leaving prostitution
7/1/2007	6/30/2010	San Francisco Network Ministries Housing Corp.	\$ 195,347	Safehouse for women leaving prostitution
7/1/2008	6/30/2009	San Francisco Pretrial Diversion Project	\$ 83,505	Placing individuals from the criminal justice system in substance abuse treatment, counseling, housing, mental health, education and/or community services programs
7/1/2008	6/30/2011	San Francisco Study Center	\$ 422,988	Support for the Immunization Program
3/1/2007	6/30/2010	San Francisco Suicide Prevention	\$ 342,027	Nightline phone crisis hotline
3/1/2009	6/30/2013	San Francisco Suicide Prevention	\$ 520,000	Nightline phone crisis hotline
7/1/2009	6/30/2011	San Francisco Suicide Prevention	\$ 1,051,180	Mental health crisis services
7/1/2007	6/30/2010	Shanti Project	\$ 1,080,000	Integrated Case Management for persons with HIV
3/1/2008	6/30/2011	Shanti Project	\$ 1,215,000	Integrated Case Management for persons with HIV
3/1/2008	6/30/2011	Shanti Project	\$ 130,000	HIV Planning Council Support Services
7/1/2008	6/30/2011	Shanti Project	\$ 1,300,000	Support services for the HIV Planning Council
7/1/2009	6/30/2014	Shanti Project	\$ 691,615	Support services for the Lifelines program and Mobile Mammography Van
3/1/2011	6/30/2015	Shanti Project	\$ 861,248	Emotional and practical support services for people with HIV/AIDS
7/1/2009	6/30/2011	Special Service for Groups	\$ 1,800,000	Support services for the HIV Planning Council
7/1/2008	8/31/2011	St. Vincent de Paul Society of San Francisco	\$ 446,880	Mental health services for elementary school-aged children
7/1/2007	6/30/2010	Stop AIDS Project	\$ 466,502	Direct Access to Housing for chronic alcoholics at Arlington Hotel
7/1/2010	6/30/2010	Stop AIDS Project	\$ 84,000	Face to Face Outreach and community-based STD education and research
7/1/2009	6/30/2011	Sunny Hills Services	\$ 84,000	Face to Face Outreach and community-based STD education and research
7/1/2009	6/30/2011	Swords to Plowshares	\$ 568,311	Mental health and substance abuse services for children
3/1/2007	6/30/2010	Tenderloin Health	\$ 1,085,848	Mental health services for veterans
7/1/2007	6/30/2010	Tenderloin Health	\$ 841,707	Emergency Housing
7/1/2008	8/31/2010	Tenderloin Health	\$ 1,697,835	Housing for people who are chronically homeless and exiting criminal justice institutions
3/1/2009	6/30/2013	Tenderloin Health	\$ 1,222,509	Transitional housing at the Kinney Hotel
9/30/2009	9/29/2013	Tenderloin Health	\$ 3,600,000	HIV Health Services - Centers of Excellence
			\$ 75,000	HIV Research projects and confidential counseling

Start Date	End Date	Vendor Name	Amount	Service Type
S.F. Administrative Code Chapter 21.42: Professional Services Contracts for Health and Behavioral Health Services and Support				
7/1/2009	6/30/2011	Tenderloin Housing Clinic	\$ 580,073	Central City SRC Collaborative
7/1/2008	6/30/2011	Tenderloin Neighborhood Development Corp.	\$ 595,224	Property management for supportive housing at Riz and Dalt Hotels
7/1/2009	6/30/2011	Thunder Road	\$ 230,720	Mental health and substance abuse services for adolescents
7/1/2006	12/31/2010	Tides Center	\$ 1,022,036	Preventative and health care services for uninsured women
3/1/2008	6/30/2012	Tides Center	\$ 1,209,600	Needle exchange services to youth
3/1/2009	6/30/2012	Tides Center	\$ 1,209,600	Needle exchange services to youth
7/1/2008	8/31/2011	TODCO	\$ 588,517	Direct Access to Housing for chronic alcoholics at Bayanhan, Knox and Isabel Hotels
3/1/2008	6/30/2011	UCSF AIDS Health Project	\$ 537,600	Cognitive Impairment - HUB of Expertise
3/1/2008	6/30/2011	UCSF AIDS Health Project	\$ 1,075,800	Mental health crisis services
7/1/2008	6/30/2011	UCSF AIDS Health Project	\$ 150,000	Return to Work Project for persons with HIV/AIDS
7/1/2008	6/30/2010	UCSF AIDS Health Project	\$ 328,000	Services for persons with HIV/AIDS
7/1/2008	6/30/2011	UCSF Committee on Human Research	\$ 150,000	Internal Review Board for Human Rights Research Protocol
7/1/2008	6/30/2011	UCSF Department of Pediatrics	\$ 500,000	HIV/AIDS pediatric primary care services
3/1/2008	6/30/2011	UCSF SFGH Psychiatry Department	\$ 540,000	Medical and psychiatric clinical services
3/1/2007	6/30/2010	University of the Pacific School of Dentistry	\$ 1,760,159	Centralized comprehensive dental services for people w/ HIV/AIDS
3/1/2010	6/30/2013	University of the Pacific School of Dentistry	\$ 1,905,000	HIV CARE - dental services
7/1/2009	6/30/2011	Victor Treatment Centers	\$ 618,521	Mental health intensive Day Treatment services and education in living skills for youth with hearing impairments
7/1/2009	6/30/2011	Volunteer Center	\$ 475,576	Mental health services
3/1/2007	6/30/2010	Walden House	\$ 255,942	Planetree Housing Program
3/1/2007	6/30/2010	Walden House	\$ 4,327,612	Comprehensive monitored residential detox services
3/1/2008	6/30/2011	Westside Community Mental Health Center	\$ 650,000	Home care/hospice/attendant care services
3/1/2009	6/30/2013	Westside Community Mental Health Center	\$ 6,272,000	HIV Health Services - Centers of Excellence
7/1/2009	6/30/2011	YMCA of San Francisco	\$ 1,942,911	Mental health and substance abuse services for youth
7/1/2009	6/30/2011	Youth Leadership Institute	\$ 593,647	Substance abuse prevention services for youths and adults



Office of the Public Defender
City and County of San Francisco

cpage ml

RECEIVED
BOARD OF SUPERVISORS
SAN FRANCISCO

Jeff Adachi
Public Defender
Teresa Caffese
Chief Attorney

2009 JUL 17 AM 10:46

BY: *MS*

July 15, 2009

Board of Supervisors
C/o Clerk of the Board
City Hall, Room 244

RE: Sole Source Contracts for FY 2008-2009

Dear Madam Clerk:

The Public Defender's office has no sole source contract for the fiscal year 2008/2009. Please feel free to contact me at 553-1677 if you have any questions. Thank you.

Very truly yours,

Angela Auyong
Executive Assistant

City County of San Francisco

cpagel ml

OFFICE OF THE SHERIFF



Michael Hennessey
SHERIFF

415 - 554 - 7225

July 16, 2009
SHF: 09-090

Angela Calvillo, Clerk of the Board
Board of Supervisors
1 Dr. Carlton B. Goodlett Place, Room 244
San Francisco, CA 94102-4689

Dear Ms. Calvillo,

The annual report to the Board of Supervisors on sole source contracts entered into for fiscal year 2008-2009 is attached as requested.

Please contact Maureen Gannon, Chief Financial Officer, at 415 554-4316 if you have any questions.

Thank you.

Sincerely,

Michael Hennessey
MICHAEL HENNESSEY
Sheriff

RECEIVED
BOARD OF SUPERVISORS
SAN FRANCISCO
2009 JUL 16 PM 2:46
BY *[Signature]*

San Francisco Sheriff's Department
List of Sole Source Contracts in Fiscal Year 2008-2009

Term	Vendor	Amount	Reason
07/01/08-06/30/09	Air Exchange, Inc.	\$92,982	Zimek Room and Vehicle Decontamination System is a Dri-Mist Micro-Particle Generator that breaks down the specifically formulated disinfectant solution into microscopic negatively charged ion particles used to treat inmate intake cells. Zimek Systems holds the patent and is the sole manufacturer, and Air Systems is the only authorized sales representative of Zimek.
07/01/08-06/30/09	Pivot Interior, Inc.	\$10,146	This service is needed for design & supplies on reconfiguring four existing work stations into six stations-adding two new workstations for the Finance Staff's work area located at City Hall, Room #456. Pivot has the exclusive contract rights to furnish City Hall building with Herman Miller Ethospace modular furniture and can also ensure that specific fabric and materials to maintain the overall "City Hall Look" and the integrity of the building is not compromised under any condition.
07/01/08-06/30/09	Rapid Notify, Inc.	\$12,075	This is an annual database subscription fee to allow access for proprietary telecommunication systems, for as-needed automated telephone alerts to communities in San Mateo County regarding any emergencies arising from San Francisco County Jails located in San Bruno.
07/01/08-06/30/09	San Bruno Garbage Co. Inc.	\$120,000	San Bruno Garbage is the sole source garbage collector for all San Bruno addresses under the terms of the San Bruno Municipal Code. The San Francisco County Jails located in San Bruno fall under this requirement.
07/01/08-06/30/09	Sirron Software Corporation	\$10,252	Sirron supports and maintains it's proprietary software for the department's Civil division. The software controls the entire Civil process, including fee processing, accounting, document tracking and more.

orig: GJ
cc: B+F comm
AC, RC, cpage.

NANCY WUERFEL

SAN FRANCISCO, CA 94116

July 16, 2009

TO; Members, Budget and Finance Committee
FROM: Nancy Wuerfel
415-731-6432 *Nancy Wuerfel*
RE; AAO for FY June 30, 2010 **Administrative Provisions sec. 12.20**

RECEIVED
BOARD OF SUPERVISORS
SAN FRANCISCO
2009 JUL 16 PM 3:53
BY *RC*

It has just come to my attention that there is a flaw in the Interim Consolidated Budget and AAO on page 156, section 12.20 "Generally Accepted Principles of Financial Statement Presentation."

This section authorizes the Controller "to make adjustments to the departmental budgets as part of the year-end closing process to conform amounts to the Charter provisions and generally accepted principles of financial statement presentation."

However, there is no standard entitled "generally accepted principles of financial statement presentation." There is an accounting standard entitled "Generally Accepted Accounting Principles" established by the Government Accounting Standards Board that is implied in this phrase, but not specifically stated.

Since the AAO is an Ordinance that governs the city's budget, I would like the standards for governing the Consolidated Budget to be clearly articulated in the Ordinance and not just implied. A change in language to an unambiguous reference to "Generally Accepted Accounting Principles" (GAAP) is needed.

I believe that this issue is a result of oversight in proof reading the Ordinance. Annually, the Controller does prepare the CAFR in conformance with the principles and standards set by the Government Accounting Standards Board that established GAAP.

It should be a straight-forward issue to simply revise the language to reflect what the City is already doing, so that the citizens know the City is held to this standard. If there were any opposition to clarifying the accounting standards in the Budget Ordinance, then I would like to know the reason why this cannot or should not be done.

cc: ✓ Clerk, Board of Supervisors
Ben Rosenfeld, City Controller

5

Office of the Mayor
City & County of San Francisco



Gavin Newsom

orig: Rules Clerk
c: ACIRC, (page)

July 13, 2009

Angela Calvillo
Clerk of the Board, Board of Supervisors
San Francisco City Hall
1 Carlton B. Goodlett Place
San Francisco, California 94102

RECEIVED
BOARD OF SUPERVISORS
SAN FRANCISCO
2009 JUL 13 PM 4:42
BY RC

Dear Ms. Calvillo,

I have reappointed Kimberly K. Brandon as a member of the Port Commission effective today, July 13, 2009. The term of Kimberly K. Brandon will expire on May 1, 2013.

Please see the attached biography which will illustrate that Kimberly K. Brandon's qualifications allow her to represent the communities of interest, neighborhoods and diverse populations of the City and County.

Should you have any questions, please contact my Liaison to Commissions, Jason Chan at 415-554-6253.

Sincerely,

Gavin Newsom
Mayor

6



Notice of Appointment

July 13, 2009

Honorable Board of Supervisors:

I hereby reappoint Kimberly K. Brandon to serve as member of the Port Commission for a 4-year term commencing July 13, 2009.

I am confident that Kimberly K. Brandon will serve our community well. Attached are her qualifications to serve, which demonstrate how the appointment represents the communities of interest, neighborhoods and diverse populations of the City and County of San Francisco.

I encourage your support and am pleased to advise you of this appointment.

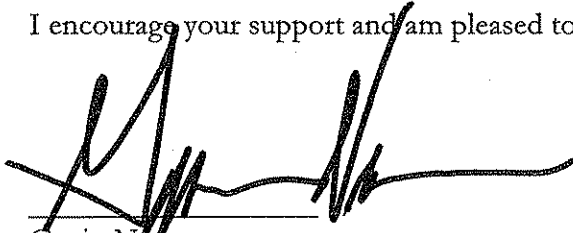

Gavin Newsom
Mayor

FILE NO.

MOTION NO.

1 [Confirming the reappointment of Kimberly K. Brandon to the San Francisco Port
Commission.]

2
3 **Motion confirming the reappointment of Kimberly K. Brandon to the San Francisco Port**
4 **Commission for a four-year term ending May 1, 2013**

5
6 MOVED, That the Board of Supervisors of the City and County of San Francisco does
7 hereby confirm the reappointment by the Mayor of the following designated person as a
8 member of the San Francisco Port Authority, pursuant to Section 4.114 of the San Francisco
9 Charter, for the term specified:

10 Kimberly K. Brandon, to serve a four-year term ending May 1, 2013.

Kimberly K. Brandon
788 Jamestown Avenue
San Francisco, CA 94124
(415) 468-1290

SUMMARY:

A successful private banker and wealth advisor with over fifteen years experience in the development, distribution and management of diversified retail and business financial products. Demonstrated leadership abilities and marketing success in the integration of investment management and credit products.

EXPERIENCE:

Senior Vice President & Wealth Advisor 2004- Present
Morgan Stanley

A successful Wealth Advisor in the Individual Investor Group. Currently managing approximately \$250 million in fixed income and equity assets. Working with high net worth individuals, endowments, foundations and middle market institutional clients. Graduate of Morgan Stanley's prestigious Wealth Advisor Program an Certified Wealth Strategist, a select group of investment professionals chosen by Morgan Stanley Senior Executive Management. Currently only 300 Wealth Advisors out of ten thousand Financial Advisors Companywide.

Vice President 2000- 2004
Relationship Manager
Bank of America NT & SA
Private Bank

Managed all aspects of banking and investment relationships for affluent individuals and their families. Specialize in creating and implementing individualized financial plans to solve complicated wealth management issues and creating custom credit solutions as needed. Consult with existing and prospective clients on investment alternatives, fiduciary and estate planning services and credit options offered by Bank of America while coordinating servicing activities.

Commissioner 1997-Present
San Francisco Port Commission

Past President 2000-2002, Vice President 1998-2000/2002-2004/2006-2007. Currently responsible for setting governmental policy and direction on all maritime and waterfront, real estate and related issues impacting San Francisco's Port.

Fiduciary oversight and responsibilities for estimated \$1 Billion in capital improvements. Commission responsibility for management of 7.5 miles of prime real estate, including Fisherman's Wharf, Pier 39, Pacific Bell Park, Ferry Building, Maritime and transportation facilities.

Direct reporting relationship with the Mayor, City Attorney and Board of Supervisors.

Premier Banking Manager 1986-2000
Assistant Vice President
Wells Fargo Bank N.A.

Successfully developed and retained one of the programs largest portfolio's of high valued mass affluent customers.

Successfully implemented fee based revenue generating sales strategies for investment, asset and liability products.

Portfolio exceeded \$100 mil. in combined asset and liability products.

Annual sales of asset and liability products exceeding \$40 million.

EDUCATION:

San Francisco State University
Bachelor of Arts/Psychology Degree

REGISTRATION:

NASD Series 7, 63 and 66
CA Life and Disability License (expired)

BOARD AFFILIATIONS:

San Francisco Port Commission
Museum of African Diaspora, Board Member
Young Scholars, Inc. Board Member
PACT, Inc. Board Member

orig: Rules Clerk
C: AC, RC c page

Office of the Mayor
City & County of San Francisco



Gavin Newsom

July 13, 2009

Angela Calvillo
Clerk of the Board, Board of Supervisors
San Francisco City Hall
1 Carlton B. Goodlett Place
San Francisco, California 94102

Dear Ms. Calvillo,

Pursuant to the Charter Section 3.100 (17), I have reappointed Larry Martin as a member of the Recreation and Parks Commission effective today, July 13, 2009, and the term of Larry Martin will expire on June 27, 2013.

Please see the attached biography which will illustrate that Larry Martin's qualifications allow him to represent the communities of interest, neighborhoods and diverse populations of the City and County.

Should you have any questions, please contact my Liaison to Commissions, Jason Chan at 415-554-6253.

Sincerely,

Gavin Newsom
Mayor

7



Notice of Appointment

July 13, 2009

Honorable Board of Supervisors:

I hereby reappoint Larry Martin to serve as member of the Recreation and Parks Commission for a 4-year term commencing July 13, 2009, in accordance with the 1996 Charter, Section 3.100, (17).

I am confident that Larry Martin will serve our community well. Attached are his qualifications to serve, which demonstrate how the appointment represents the communities of interest, neighborhoods and diverse populations of the City and County of San Francisco.

I encourage your support and am pleased to advise you of this appointment.

A handwritten signature in black ink, appearing to read "Gavin Newsom", written over a horizontal line.

Gavin Newsom
Mayor

LAWRENCE B. MARTIN

San Francisco, CA. 94132

Martial Status: Married
Wife: Francine Martin
Daughters: Karen Martin
Iris Martin

EDUCATION

A.A. Degree, Merritt College, Oakland, California, 1975
MAJOR: Labor and Urban Studies

Labor and Urban Studies Program, University of California
Labor Institute, Berkeley, California, 1972 - 1975

Labor Management School, University of San Francisco
1969 - 1971

COURSE WORK EXPERIENCE

American Labor Movement, Legal Foundations Labor Law and Minority Rights,
Labor Relations Laws, Collective Bargaining, Economics for Labor and
Community Leadership;

Grievance Handling and Arbitration, Responsibilities and Psychology of
Leadership, Uses of Accounting in Labor Relations and Union Administrations,
Communications for Labor Leadership, Racial and Ethnic Identity in American
Society;

Grievance and Arbitration in Public Employment, Avoidance and Resolution of
Grievances.

BUSINESS EXPERIENCE

1980 - Present	International Representative, Transport Workers Union of America
1974 - 1979	President, Local 250-A, Transport Workers Union of America, San Francisco, California
1968 - 1974	Full-time Union Steward, Presidio Division, San Francisco Municipal Railway
1966 - 1968	Platform Operator, San Francisco Municipal Railway

LAWRENCE B. MARTIN

PAGE 2.

ORGANIZATIONS

- 1984 - Present San Francisco Human Rights Commission
- 1977 - Present International Executive Council and Board Member, Transport Workers Union of America
- 1981 - Present California State Conference, Legislative Director, Transport Workers Union of America
- 1990 - 1992 Western Regional Representative, A. Phillip Randolph Institute
- 1981 - 1990 President, California State Chapter, A. Phillip Randolph Institute
- 1976 - Present Executive Board Member, San Francisco Labor Council
- 1976 - Present Labor Advisory Board, San Francisco Community College
- 1983 - 1988 Board of Directors, United Cerebral Palsy
- 1976 - 1979 Labor Advisory Board, University of California Labor Institute
- 1976 - 1979 Labor Advisory Board, San Francisco State University
- 1977 - 1979 Labor Advisory Board, University of San Francisco, Labor Management School
- 1977 - 1979 Chairperson, Coordinating Council of Bay Area Transit Unions
- 1977 Organizer and Founder, Coordinating Council of Bay Area Transit Unions
- 1978 - 1979 Member, Regional Transit Productivity Committee, Metropolitan Transportation Committee

OTHER SERVICE AND AFFILIATION

- * Active member of the Transport Workers Union of America International Union and TWU Local 250-A, San Francisco
- * Active member of San Francisco Black Leadership Forum
- * Active Member of the NAACP, San Francisco
- * Served on the Mayor's Joint Committee on SF Job Fair
- * Served on Mayor's Taskforce on Family Policy
- * Served on Mayor's Graffiti Prevention Advisory Committee
- * Served on Mayor's Taskforce on Domestic Partners
- * Served on Mayor's Joint Commission on Crack Cocaine
- * Served on Mayor's African American Parity Taskforce
- * Member of San Franciscans for Improved Transportation Committee

Office of the Mayor
City & County of San Francisco



Orig: Public Clerk
cc: AC, RC, c page
Gavin Newsom

July 13, 2009

Angela Calvillo
Clerk of the Board, Board of Supervisors
San Francisco City Hall
1 Carlton B. Goodlett Place
San Francisco, California 94102

RECEIVED
BOARD OF SUPERVISORS
SAN FRANCISCO
2009 JUL 13 PM 4:42
BY [Signature]

Dear Ms. Calvillo,

Pursuant to the Charter Section 3.100 (17), I have reappointed David Lee as a member of the Recreation and Parks Commission effective today, July 13, 2009, and the term of David Lee will expire on June 27, 2013.

Please see the attached biography which will illustrate that David Lee's qualifications allow him to represent the communities of interest, neighborhoods and diverse populations of the City and County.

Should you have any questions, please contact my Liaison to Commissions, Jason Chan at 415-554-6253.

Sincerely,

Gavin Newsom
Mayor

8



Notice of Appointment

July 13, 2009

Honorable Board of Supervisors:

I hereby reappoint David Lee to serve as member of the Recreation and Parks Commission for a 4-year term commencing July 13, 2009, in accordance with the 1996 Charter, Section 3.100, (17).

I am confident that David Lee will serve our community well. Attached are his qualifications to serve, which demonstrate how the appointment represents the communities of interest, neighborhoods and diverse populations of the City and County of San Francisco.

I encourage your support and am pleased to advise you of this appointment.

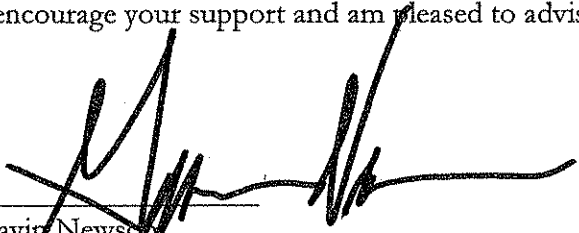

Gavin Newsom
Mayor

David E. Lee

David E. Lee is Executive Director of Chinese American Voters Education Committee (CAVEC), a private, non-profit civic education and research organization dedicated to increasing Asian American civic participation. He was appointed to the San Francisco Recreation and Park Commission by Mayor Gavin Newsom in 2005.

Mr. Lee is also a Lecturer of Political Science at San Francisco State University. He is active on several boards including KQED Public Broadcasting, Wells Fargo Community Advisory Board, New America Media and the San Francisco Lee Federal Credit Union. Mr. Lee also serves on the San Francisco Planning and Urban Research ("SPUR") Advisory Board.

Mr. Lee has a BA from Hamilton College and a MA in Political Science from SFSU. Mr. Lee is the recipient of fellowships to Harvard Kennedy School's Senior Executives In State and Local Government Program, Harvard Business School's Strategic Perspectives for Non-profit Leaders Program and Stanford Business School's Executive Program For Non-profit Leaders Program.

In 2002, he received the San Francisco Foundation Community Leadership Award.

David's other recognitions for public service include the Wallace A. Gerbode Foundation Fellowship and the David Jenkins Award for Community Service.

orig: Rules Clerk
c: AC, RC, c page

Office of the Mayor
City & County of San Francisco



Gavin Newsom

July 13, 2009

Angela Calvillo
Clerk of the Board, Board of Supervisors
San Francisco City Hall
1 Carlton B. Goodlett Place
San Francisco, California 94102

RECEIVED
BOARD OF SUPERVISORS
SAN FRANCISCO

2009 JUL 13 PM 4:12

BY RA

Dear Ms. Calvillo,

Pursuant to the Charter Section 3.100 (17), I have appointed Amelia D. Yaros as a member of the Residential Rent Stabilization and Arbitration Board effective today, July 13, 2009. Amelia D. Yaros will fill a seat that was previously held by Anthony Justman, and the term of Amelia D. Yaros will expire on October 1, 2011.

Please see the attached biography which will illustrate that Amelia D. Yaros' qualifications allow her to represent the communities of interest, neighborhoods and diverse populations of the City and County.

Should you have any questions, please contact my Liaison to Commissions, Jason Chan at 415-554-6253.

Sincerely,

Gavin Newsom
Mayor

9



Notice of Appointment

July 13, 2009

Honorable Board of Supervisors:

I hereby appoint Amelia D. Yaros to serve as member of the Residential Rent Stabilization and Arbitration Board for a 4-year term commencing July 13, 2009, in accordance with the 1996 Charter, Section 3.100, (17).

I am confident that Amelia D. Yaros will serve our community well. Attached are her qualifications to serve, which demonstrate how the appointment represents the communities of interest, neighborhoods and diverse populations of the City and County of San Francisco.

I encourage your support and am pleased to advise you of this appointment.

A handwritten signature in black ink, appearing to read "Gavin Newsom", written over a horizontal line.

Gavin Newsom
Mayor

AMELIA D. YAROS

ATTORNEY AT LAW

6324 CALIFORNIA STREET #3, SAN FRANCISCO, CALIFORNIA 94121
TELEPHONE: 415-317-5490 E-MAIL: AYAROS.LAW@GMAIL.COM

EDUCATION

UNIVERSITY OF SAN FRANCISCO SCHOOL OF LAW, San Francisco, CA

Juris Doctorate, 2002

Law Faculty Scholarship, Criminal Law Clinic, Mediation Clinic

UNIVERSITY OF OREGON, Eugene, OR

Bachelor of Arts, English Literature, 1997

EMPLOYMENT HISTORY

LAW OFFICE OF AMELIA D. YAROS, San Francisco, CA

Principal, June 2006 to Present

LYNCH, GILARDI & GRUMMER, San Francisco, CA

Senior Counsel, June 2006 to June 2008; Associate Attorney, June 2004 to May 2005

SELMAN BREITMAN, San Francisco, CA

Associate Attorney, May 2005 to December 2005

SCOPELITIS, GARVIN, LIGHT & HANSON, San Francisco, CA

Associate Attorney, August 2002 to June 2004

LEGAL PRACTICE

PRINCIPAL PRACTICE AREAS

Personal Injury and Property Damage Defense – representation of parties in actions ranging from wrongful death and catastrophic injury to simple slip and trip cases.

Employee Rights – representation of employees in individual and multi-party actions in claims regarding California Wage & Hour and other Labor Code violations, Wrongful Termination, and FEHA claims.

Juvenile Dependency – representation of children and parents in juvenile dependency court proceedings relating to child welfare and protection of parental rights.

ADDITIONAL PRACTICE AREAS - Insurance Coverage, Transportation and Cargo Loss, Products Liability, Product Warranty, and Restraint of Trade.

PRACTICAL EXPERIENCE

Advisory – Development of litigation policies, plans and strategies, including counseling on pre-litigation disputes. Preparing coverage opinions for insurers and coverage position letters to insureds, including policy analysis and claim evaluation.

Depositions and Discovery – Development of efficient and effective discovery plans. Taking and defending depositions of parties, witnesses, and experts.

Law and Motion – Preparation of papers and presentation of oral arguments on motions for summary judgment, demurrers, motions to strike, motions for good faith settlement, discovery disputes, and failure to join necessary parties.

Alternative Dispute Resolution – Representation of individual and corporate clients at mediations; arbitrations; early neutral evaluations; and settlement conferences.

Trial – Preparation for trial including pre-trial motions, witness preparation, preparation of jury instructions and verdict forms, identification of exhibits, and selection of deposition testimony for use at trial. Second-chaired two favorable jury trials, one securing jury verdict in excess of \$7m.

COMMUNITY WORK – Member of the Family Justice program of the Bar Association of San Francisco providing family law services to low-income individuals in San Francisco.

BIOGRAPHICAL INFORMATION

San Francisco native: homeowner since 2007.

Office of the Mayor
City & County of San Francisco



orig: Roles Clerk
c: AC, RC, c page

Gavin Newsom

July 13, 2009

Angela Calvillo
Clerk of the Board, Board of Supervisors
San Francisco City Hall
1 Carlton B. Goodlett Place
San Francisco, California 94102

RECEIVED
BOARD OF SUPERVISORS
SAN FRANCISCO

2009 JUL 13 PM 4:42

BY _____
RC

Dear Ms. Calvillo,

Pursuant to the Charter Section 3.100 (17), I have reappointed Dennis Normandy as a member of the Civil Service Commission effective today, July 13, 2009, and the term of Dennis Normandy will expire on June 30, 2013.

Please see the attached biography which will illustrate that Dennis Normandy's qualifications allow him to represent the communities of interest, neighborhoods and diverse populations of the City and County.

Should you have any questions, please contact my Liaison to Commissions, Jason Chan at 415-554-6253.

Sincerely,

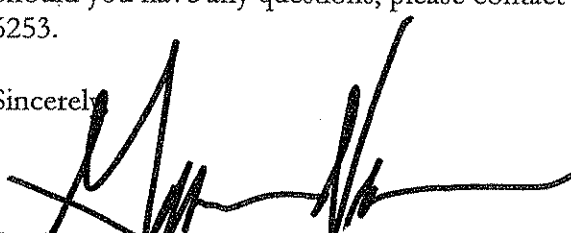
Gavin Newsom
Mayor

10



Notice of Appointment

July 13, 2009

Honorable Board of Supervisors:

I hereby reappoint Dennis Normandy to serve as member of the Civil Service Commission for a 4-year term commencing July 13, 2009, in accordance with the 1996 Charter, Section 3.100, (17).

I am confident that Dennis Normandy will serve our community well. Attached are his qualifications to serve, which demonstrate how the appointment represents the communities of interest, neighborhoods and diverse populations of the City and County of San Francisco.

I encourage your support and am pleased to advise you of this appointment.

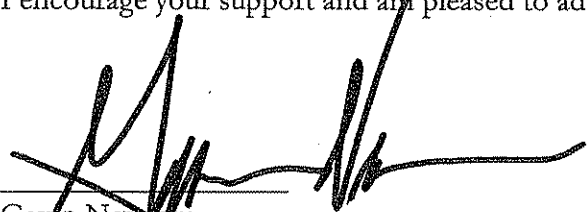

Gavin Newsom
Mayor

August, 2008

E. DENNIS NORMANDY

E. Dennis Normandy is an independent businessman, community leader, and public official.

He has served in the administrations of 5 San Francisco Mayors: as Library Commissioner for Dianne Feinstein and Art Agnos, and as Public Utilities Commissioner for Frank Jordan, Willie L. Brown, Jr., and Gavin Newsom. Normandy's more than 14 years and 4 terms as President of the SFPUC is unprecedented, and characterized by his unwavering insistence on holding the multi-billion-dollar agency to the highest standards of service, accountability and profitability, on employing best business and science-based management practices, and on including all stakeholders in an open process of governance. He has acquired a reputation for inclusion as well as civility, "hard on issues, but soft on people".

In 1990 he served in then Governor George Deukmejian's CALIFORNIA TASK FORCE FOR THE STUDY OF ASIA.

Normandy has contributed both locally and nationally to the positive visibility and empowerment of ethnic communities in the United States. He was a featured columnist for the nationally-circulated PHILIPPINE NEWS and host on public television's ASIAN JOURNAL. He was President of the NATIONAL FILIPINO AMERICAN COUNCIL, an advocacy network of organizations and individuals throughout the country. He was Chairman of the NATIONAL ASIAN AND PACIFIC AMERICAN COALITION, linking national leaders of numerous ethnic communities. For 16 years he has chaired the Mayor's SAN FRANCISCO-MANILA SISTER CITY COMMITTEE, the preeminent trade and cultural bridge between the two cities. He received a PHILIPPINE PRESIDENTIAL AWARD citing his work as ambassador of good will between the United States and the Philippines.

Normandy was born into a French-American-Filipino family that pioneered bus transit systems in the Philippines. He was schooled in both the Humanities and Business at leading Jesuit universities, and attended Harvard's Kennedy School of Government. He settled in San Francisco at age 25, after having served concurrently on the boards of 5 privately-held Manila corporations while managing advertising for STANDARD OIL AGRICHEMICALS in the Far East. By his mid-thirties, he was directing U.S. and worldwide advertising at the San Francisco headquarters of DEL MONTE, the world's largest processor of canned fruits and vegetables. He later took the post of Promotions Director at FOOTE, CONE & BELDING, a top advertising agency with operations in 73 countries. In 1984 he made the transition from corporate executive to independent businessman.

For over 2 decades he was Chairman and CEO of THE PSN GROUP, a consortium providing a spectrum of marketing, communications, and graphic design services in the Bay Area and the Pacific Rim. He recently formed INFRASTRUCTURE DEVELOPMENT GROUP, LLC, which brings state-of-the-art environmental protection technology to Asia.

Normandy has been married to Lynda Teehankee for 45 years, and the couple has 3 sons and daughters in law with 5 grandchildren.

BOARD of SUPERVISORS



City Hall
Carlton B. Goodlett Place, Room 244
San Francisco 94102-4689
Tel. No. 554-5184
Fax No. 554-5163
TDD/TTY No. 554-5227

RECEIVED
BOARD OF SUPERVISORS
SAN FRANCISCO
2009 JUL 15 PM 4:53
PN

MEMORANDUM

Date: July 15, 2009
To: Honorable Members, Board of Supervisors
From: Angela Calvillo, Clerk of the Board *A. Calvillo*
Subject: APPOINTMENTS BY THE MAYOR

The Mayor has submitted appointments to the following Board and Commissions:

- Larry Martin, Recreation and Parks Commission
- David Lee, Recreation and Parks Commission
- Amelia D. Yaros, Residential Rent Stabilization and Arbitration Board
- Dennis Normandy, Civil Service Commission

Under the Board's Rules of Order, a Supervisor can request a hearing on an appointment by notifying the Clerk in writing.

Upon receipt of such notice, the Clerk shall refer the appointment to the Rules Committee so that the Board may consider the appointment and act within thirty days of the appointment as provided in Section 3.100(17) of the Charter.

Please notify me in writing by **2:00 p.m., Monday, July 20, 2009**, if you wish any appointment to be scheduled before the Rules Committee.

Attachments

orig: Rules Clerk
C-AC, RC c page.

Office of the Mayor
City & County of San Francisco



Gavin Newsom

July 13, 2009

Angela Calvillo
Clerk of the Board, Board of Supervisors
San Francisco City Hall
1 Carlton B. Goodlett Place
San Francisco, California 94102

Dear Ms. Calvillo,

Pursuant to the Charter Section 3.100 (17), I have reappointed Larry Martin as a member of the Recreation and Parks Commission effective today, July 13, 2009, and the term of Larry Martin will expire on June 27, 2013.

Please see the attached biography which will illustrate that Larry Martin's qualifications allow him to represent the communities of interest, neighborhoods and diverse populations of the City and County.

Should you have any questions, please contact my Liaison to Commissions, Jason Chan at 415-554-6253.

Sincerely,

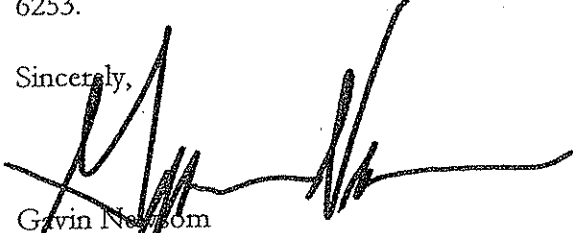
Gavin Newsom
Mayor



Notice of Appointment

July 13, 2009

Honorable Board of Supervisors:

I hereby reappoint Larry Martin to serve as member of the Recreation and Parks Commission for a 4-year term commencing July 13, 2009, in accordance with the 1996 Charter, Section 3.100, (17).

I am confident that Larry Martin will serve our community well. Attached are his qualifications to serve, which demonstrate how the appointment represents the communities of interest, neighborhoods and diverse populations of the City and County of San Francisco.

I encourage your support and am pleased to advise you of this appointment.

A handwritten signature in black ink, appearing to read "Gavin Newsom", written over a horizontal line.

Gavin Newsom
Mayor

LAWRENCE B. MARTIN

San Francisco, CA. 94132

Martial Status: Married
Wife: Francine Martin
Daughters: Karen Martin
Iris Martin

EDUCATION

A.A. Degree, Merritt College, Oakland, California, 1975
MAJOR: Labor and Urban Studies

Labor and Urban Studies Program, University of California
Labor Institute, Berkeley, California, 1972 - 1975

Labor Management School, University of San Francisco
1969 - 1971

COURSE WORK EXPERIENCE

American Labor Movement, Legal Foundations Labor Law and Minority Rights,
Labor Relations Laws, Collective Bargaining, Economics for Labor and
Community Leadership;

Grievance Handling and Arbitration, Responsibilities and Psychology of
Leadership, Uses of Accounting in Labor Relations and Union Administrations,
Communications for Labor Leadership, Racial and Ethnic Identity in American
Society;

Grievance and Arbitration in Public Employment, Avoidance and Resolution of
Grievances.

BUSINESS EXPERIENCE

1980 - Present

International Representative, Transport Workers
Union of America

1974 - 1979

President, Local 250-A, Transport Workers Union
of America, San Francisco, California

1968 - 1974

Full-time Union Steward, Presidio Division,
San Francisco Municipal Railway

1966 - 1968

Platform Operator, San Francisco Municipal Railway

LAWRENCE B. MARTIN

PAGE 2.

ORGANIZATIONS

- 1984 - Present San Francisco Human Rights Commission
- 1977 - Present International Executive Council and Board Member, Transport Workers Union of America
- 1981 - Present California State Conference, Legislative Director, Transport Workers Union of America
- 1990 - 1992 Western Regional Representative, A. Phillip Randolph Institute
- 1981 - 1990 President, California State Chapter, A. Phillip Randolph Institute
- 1976 - Present Executive Board Member, San Francisco Labor Council
- 1976 - Present Labor Advisory Board, San Francisco Community College
- 1983 - 1988 Board of Directors, United Cerebral Palsy
- 1976 - 1979 Labor Advisory Board, University of California Labor Institute
- 1976 - 1979 Labor Advisory Board, San Francisco State University
- 1977 - 1979 Labor Advisory Board, University of San Francisco, Labor Management School
- 1977 - 1979 Chairperson, Coordinating Council of Bay Area Transit Unions
- 1977 Organizer and Founder, Coordinating Council of Bay Area Transit Unions
- 1978 - 1979 Member, Regional Transit Productivity Committee, Metropolitan Transportation Committee

OTHER SERVICE AND AFFILIATION

- * Active member of the Transport Workers Union of America International Union and TWU Local 250-A, San Francisco
- * Active member of San Francisco Black Leadership Forum
- * Active Member of the NAACP, San Francisco
- * Served on the Mayor's Joint Committee on SF Job Fair
- * Served on Mayor's Taskforce on Family Policy
- * Served on Mayor's Graffiti Prevention Advisory Committee
- * Served on Mayor's Taskforce on Domestic Partners
- * Served on Mayor's Joint Commission on Crack Cocaine
- * Served on Mayor's African American Parity Taskforce
- * Member of San Franciscans for Improved Transportation Committee

Office of the Mayor
City & County of San Francisco



*Orig: Public Clerk
cc: AC, RC, c page*
Gavin Newsom

July 13, 2009

Angela Calvillo
Clerk of the Board, Board of Supervisors
San Francisco City Hall
1 Carlton B. Goodlett Place
San Francisco, California 94102

RECEIVED
BOARD OF SUPERVISORS
CLERK OF THE BOARD
2009 JUL 13 PM 4:42
BY

Dear Ms. Calvillo,

Pursuant to the Charter Section 3.100 (17), I have reappointed David Lee as a member of the Recreation and Parks Commission effective today, July 13, 2009, and the term of David Lee will expire on June 27, 2013.

Please see the attached biography which will illustrate that David Lee's qualifications allow him to represent the communities of interest, neighborhoods and diverse populations of the City and County.

Should you have any questions, please contact my Liaison to Commissions, Jason Chan at 415-554-6253.

Sincerely,

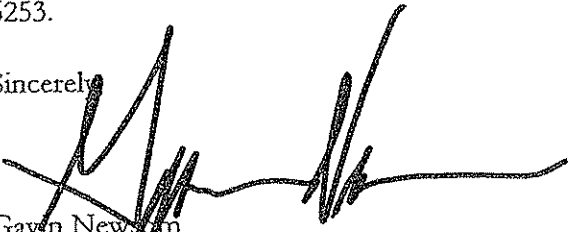
Gavin Newsom
Mayor



Notice of Appointment

July 13, 2009

Honorable Board of Supervisors:

I hereby reappoint David Lee to serve as member of the Recreation and Parks Commission for a 4-year term commencing July 13, 2009, in accordance with the 1996 Charter, Section 3.100, (17).

I am confident that David Lee will serve our community well. Attached are his qualifications to serve, which demonstrate how the appointment represents the communities of interest, neighborhoods and diverse populations of the City and County of San Francisco.

I encourage your support and am pleased to advise you of this appointment.

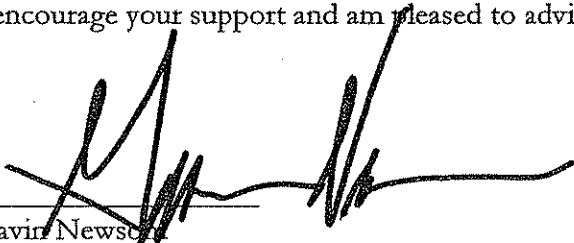
Gavin Newsom
Mayor

David E. Lee

David E. Lee is Executive Director of Chinese American Voters Education Committee (CAVEC), a private, non-profit civic education and research organization dedicated to increasing Asian American civic participation. He was appointed to the San Francisco Recreation and Park Commission by Mayor Gavin Newsom in 2005.

Mr. Lee is also a Lecturer of Political Science at San Francisco State University. He is active on several boards including KQED Public Broadcasting, Wells Fargo Community Advisory Board, New America Media and the San Francisco Lee Federal Credit Union.

Mr. Lee also serves on the San Francisco Planning and Urban Research ("SPUR") Advisory Board.

Mr. Lee has a BA from Hamilton College and a MA in Political Science from SFSU. Mr. Lee is the recipient of fellowships to Harvard Kennedy School's Senior Executives In State and Local Government Program, Harvard Business School's Strategic Perspectives for Non-profit Leaders Program and Stanford Business School's Executive Program For Non-profit Leaders Program.

In 2002, he received the San Francisco Foundation Community Leadership Award.

David's other recognitions for public service include the Wallace A. Gerbode Foundation Fellowship and the David Jenkins Award for Community Service.

Office of the Mayor
City & County of San Francisco



orig: Rules Clerk
c: AC, RC, c page

Gavin Newsom

July 13, 2009

Angela Calvillo
Clerk of the Board, Board of Supervisors
San Francisco City Hall
1 Carlton B. Goodlett Place
San Francisco, California 94102

RECEIVED
BOARD OF SUPERVISORS
SAN FRANCISCO
2009 JUL 13 PM 4:42
BY RC

Dear Ms. Calvillo,

Pursuant to the Charter Section 3.100 (17), I have appointed Amelia D. Yaros as a member of the Residential Rent Stabilization and Arbitration Board effective today, July 13, 2009. Amelia D. Yaros will fill a seat that was previously held by Anthony Justman, and the term of Amelia D. Yaros will expire on October 1, 2011.

Please see the attached biography which will illustrate that Amelia D. Yaros' qualifications allow her to represent the communities of interest, neighborhoods and diverse populations of the City and County.

Should you have any questions, please contact my Liaison to Commissions, Jason Chan at 415-554-6253.

Sincerely,

A handwritten signature in black ink, appearing to read "Gavin Newsom", written over a horizontal line.

Gavin Newsom
Mayor



Notice of Appointment

July 13, 2009

Honorable Board of Supervisors:

I hereby appoint Amelia D. Yaros to serve as member of the Residential Rent Stabilization and Arbitration Board for a 4-year term commencing July 13, 2009, in accordance with the 1996 Charter, Section 3.100, (17).

I am confident that Amelia D. Yaros will serve our community well. Attached are her qualifications to serve, which demonstrate how the appointment represents the communities of interest, neighborhoods and diverse populations of the City and County of San Francisco.

I encourage your support and am pleased to advise you of this appointment.

A handwritten signature in black ink, appearing to read "Gavin Newsom", written over a horizontal line.

Gavin Newsom
Mayor

AMELIA D. YAROS

ATTORNEY AT LAW

6324 CALIFORNIA STREET #3, SAN FRANCISCO, CALIFORNIA 94121
TELEPHONE: 415-317-5490 E-MAIL: AYAROS.LAW@GMAIL.COM

EDUCATION

UNIVERSITY OF SAN FRANCISCO SCHOOL OF LAW, San Francisco, CA

Juris Doctorate, 2002

Law Faculty Scholarship, Criminal Law Clinic, Mediation Clinic

UNIVERSITY OF OREGON, Eugene, OR

Bachelor of Arts, English Literature, 1997

EMPLOYMENT HISTORY

LAW OFFICE OF AMELIA D. YAROS, San Francisco, CA

Principal, June 2006 to Present

LYNCH, GILARDI & GRUMMER, San Francisco, CA

Senior Counsel, June 2006 to June 2008; Associate Attorney, June 2004 to May 2005

SELMAN BREITMAN, San Francisco, CA

Associate Attorney, May 2005 to December 2005

SCOPELITIS, GARVIN, LIGHT & HANSON, San Francisco, CA

Associate Attorney, August 2002 to June 2004

LEGAL PRACTICE

PRINCIPAL PRACTICE AREAS

Personal Injury and Property Damage Defense – representation of parties in actions ranging from wrongful death and catastrophic injury to simple slip and trip cases.

Employee Rights – representation of employees in individual and multi-party actions in claims regarding California Wage & Hour and other Labor Code violations, Wrongful Termination, and FEHA claims.

Juvenile Dependency – representation of children and parents in juvenile dependency court proceedings relating to child welfare and protection of parental rights.

ADDITIONAL PRACTICE AREAS - Insurance Coverage, Transportation and Cargo Loss, Products Liability, Product Warranty, and Restraint of Trade.

PRACTICAL EXPERIENCE

Advisory – Development of litigation policies, plans and strategies, including counseling on pre-litigation disputes. Preparing coverage opinions for insurers and coverage position letters to insureds, including policy analysis and claim evaluation.

Depositions and Discovery – Development of efficient and effective discovery plans. Taking and defending depositions of parties, witnesses, and experts.

Law and Motion – Preparation of papers and presentation of oral arguments on motions for summary judgment, demurrers, motions to strike, motions for good faith settlement, discovery disputes, and failure to join necessary parties.

Alternative Dispute Resolution – Representation of individual and corporate clients at mediations; arbitrations; early neutral evaluations; and settlement conferences.

Trial – Preparation for trial including pre-trial motions, witness preparation, preparation of jury instructions and verdict forms, identification of exhibits, and selection of deposition testimony for use at trial. Second-chaired two favorable jury trials, one securing jury verdict in excess of \$7m.

COMMUNITY WORK – Member of the Family Justice program of the Bar Association of San Francisco providing family law services to low-income individuals in San Francisco.

BIOGRAPHICAL INFORMATION

San Francisco native: homeowner since 2007.

Office of the Mayor
City & County of San Francisco



Gavin Newsom

orig: Rules Clerk
c: AC, RC, c page

July 13, 2009

Angela Calvillo
Clerk of the Board, Board of Supervisors
San Francisco City Hall
1 Carlton B. Goodlett Place
San Francisco, California 94102

RECEIVED
BOARD OF SUPERVISORS
GAVIN NEWSOM

2009 JUL 13 PM 4:42

BY _____
RC

Dear Ms. Calvillo,

Pursuant to the Charter Section 3.100 (17), I have reappointed Dennis Normandy as a member of the Civil Service Commission effective today, July 13, 2009, and the term of Dennis Normandy will expire on June 30, 2013.

Please see the attached biography which will illustrate that Dennis Normandy's qualifications allow him to represent the communities of interest, neighborhoods and diverse populations of the City and County.

Should you have any questions, please contact my Liaison to Commissions, Jason Chan at 415-554-6253.

Sincerely,

A handwritten signature in black ink, appearing to read "Gavin Newsom", written over a horizontal line.

Gavin Newsom
Mayor



Notice of Appointment

July 13, 2009

Honorable Board of Supervisors:

I hereby reappoint Dennis Normandy to serve as member of the Civil Service Commission for a 4-year term commencing July 13, 2009, in accordance with the 1996 Charter, Section 3.100, (17).

I am confident that Dennis Normandy will serve our community well. Attached are his qualifications to serve, which demonstrate how the appointment represents the communities of interest, neighborhoods and diverse populations of the City and County of San Francisco.

I encourage your support and am pleased to advise you of this appointment.

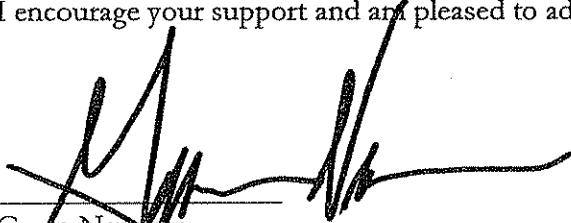

Gavin Newsom
Mayor

August, 2008

E. DENNIS NORMANDY

E. Dennis Normandy is an independent businessman, community leader, and public official.

He has served in the administrations of 5 San Francisco Mayors: as Library Commissioner for Dianne Feinstein and Art Agnos, and as Public Utilities Commissioner for Frank Jordan, Willie L. Brown, Jr., and Gavin Newsom. Normandy's more than 14 years and 4 terms as President of the SFPUC is unprecedented, and characterized by his unwavering insistence on holding the multi-billion-dollar agency to the highest standards of service, accountability and profitability, on employing best business and science-based management practices, and on including all stakeholders in an open process of governance. He has acquired a reputation for inclusion as well as civility, "hard on issues, but soft on people".

In 1990 he served in then Governor George Deukmejian's CALIFORNIA TASK FORCE FOR THE STUDY OF ASIA.

Normandy has contributed both locally and nationally to the positive visibility and empowerment of ethnic communities in the United States. He was a featured columnist for the nationally-circulated PHILIPPINE NEWS and host on public television's ASIAN JOURNAL. He was President of the NATIONAL FILIPINO AMERICAN COUNCIL, an advocacy network of organizations and individuals throughout the country. He was Chairman of the NATIONAL ASIAN AND PACIFIC AMERICAN COALITION, linking national leaders of numerous ethnic communities. For 16 years he has chaired the Mayor's SAN FRANCISCO-MANILA SISTER CITY COMMITTEE, the preeminent trade and cultural bridge between the two cities. He received a PHILIPPINE PRESIDENTIAL AWARD citing his work as ambassador of good will between the United States and the Philippines.

Normandy was born into a French-American-Filipino family that pioneered bus transit systems in the Philippines. He was schooled in both the Humanities and Business at leading Jesuit universities, and attended Harvard's Kennedy School of Government. He settled in San Francisco at age 25, after having served concurrently on the boards of 5 privately-held Manila corporations while managing advertising for STANDARD OIL AGRICHEMICALS in the Far East. By his mid-thirties, he was directing U.S. and worldwide advertising at the San Francisco headquarters of DEL MONTE, the world's largest processor of canned fruits and vegetables. He later took the post of Promotions Director at FOOTE, CONE & BELDING, a top advertising agency with operations in 73 countries. In 1984 he made the transition from corporate executive to independent businessman.

For over 2 decades he was Chairman and CEO of THE PSN GROUP, a consortium providing a spectrum of marketing, communications, and graphic design services in the Bay Area and the Pacific Rim. He recently formed INFRASTRUCTURE DEVELOPMENT GROUP, LLC, which brings state-of-the-art environmental protection technology to Asia.

Normandy has been married to Lynda Teehankee for 45 years, and the couple has 3 sons and daughters in law with 5 grandchildren.

RECEIVED
BOARD OF SUPERVISORS
SAN FRANCISCO

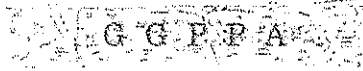

File 90716
BOS-11
GJ, c page

2009 JUL 13 PM 12:10 Golden Gate Park Preservation Alliance ©

BY

Clerk of the Board

"Destroy a public building and it can be rebuilt in a year; destroy a city woodland park and all the people living at the time will have passed away before its restoration can be effected."

William Hammond Hall, Surveyor
First Superintendent of Golden Gate Park

To: Board of Supervisors

Date: July 13, 2009

From: Katherine Howard, Steering Committee, GGPPA

Subject: Item #18, Recreation and Park Parking, 090716, BOS meeting, July 14th, 2009.

We have many concerns with charging for parking in Golden Gate Park. One particular concern is in regards to aesthetics. Any introduction of more metal posts, machines, signage, and other support for the parking stations will further add to the 'urban clutter' in the park and detract from the park-like environment, which is the whole purpose of Golden Gate Park. Some design questions are:

- What is the spacing of the stations?
- What will the stations look like?
- Where will they be located in relation to the Park landscaping?
- What kind of natural screening is planned, so that the stations do not intrude on the overall park views? For example, there may be bollards, if the stations are in the road. Metal pipe is not park-like – can there plantings or another kind of screening?
- Will there be parking lines painted on the street? We prefer a system where a ticket is purchased and left in the car window. If there are painted spaces, then the roads will lose any sylvan quality, even when the cars are absent.
- Will there be trenching for power cables, and if so, will they disturb tree roots, lawns, or planting beds?
- Will there be even more signage than there is now or other urban clutter to support this system?

We have other concerns with charging for parking in Golden Gate Park. They are listed in the attached memo .

We hope that as the parking proposal is developed, you will review the details carefully and endeavor to preserve the sylvan nature of Golden Gate Park.

Attachments:

- Questions Regarding the Proposal to Charge for Parking In Golden Gate Park, February 2, 2009
- Steering Committee members - GGPPA
- Mission Statement - GGPPA



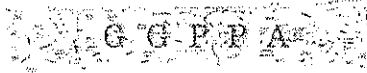

Golden Gate Park Preservation Alliance ©

"Destroy a public building and it can be rebuilt in a year; destroy a city woodland park and all the people living at the time will have passed away before its restoration can be effected."

William Hammond Hall, Surveyor
First Superintendent of Golden Gate Park

To: Recreation and Park Commission
Jared Blumenfeld, Interim General Manager, RPD
Dennis Kern, Director of Operations, RPD
Katie Petrucione, Director of Administration and Finance, RPD

From: Steering Committee: Arthur Chang, Katherine Howard, Margaret Mori, Nancy Wuerfel

Date: February 2, 2009

Subject: Questions Regarding the Proposal to Charge for Parking in Golden Gate Park

There is currently a budget proposal before RPD to charge for parking in the eastern end of Golden Gate Park. We appreciate the need to generate revenue during these difficult economic times. However, this proposal has the potential for significant impact on the Park experience for Park visitors as well as on the surrounding neighborhoods. To gain public support, we urge you to provide more details on the implementation of the plan, including the following information:

Aesthetic and infrastructure considerations:

- How will the proposed parking station system work?
- Which roads will be used for this project? Will it include the parking lots at Sharon Art Studio, the County Fair Building, and McLaren Lodge?
- What will be the aesthetic impact on the Park: additional pavement markings and signage, location of parking machines in relation to the roads and pedestrian paths, interval between machines, appearance of machines, and screening of machines from the view of Park visitors.
- What will be the construction impact of installing stations: will lawn and planting beds be torn up, major tree roots disturbed, newly-paved roads torn up?

Maintenance:

- Who will maintain the machines and has this cost been factored into the potential revenues?
- If they are maintained by RPD, will this mean additional FTE's, or will personnel be taken away from other positions, such as custodians and gardeners?

Income and use of funds

- How will the income from the Parking fees and penalty fines be allocated, both between City Departments and within RPD? How much will go to Golden Gate Park?
- What will be the pricing structure for the surface parking, and will it change for special events, parties, time of day, or day of the week?
- How will pricing compare to the Music Concourse garage and the UCSF garage?
- What is the projected revenue for this system, and what is the quantitative basis for this? Have the Saturday and Sunday closures been factored into this analysis?

Enforcement

- Who will write the tickets - DPT or the Park Rangers? If done by the Park Rangers, how many new Park Ranger positions will be funded to take care of this function?
- Will paid parking be enforced for the entire time that the Park is open, including the evenings?
- What will happen to the current 3 and 4 hour time limits? Will out-of-town commuters be able to buy a ticket for the whole day that is less costly than the UCSF or downtown garage prices?

Effect on the neighborhoods

- In order to enlist neighborhood support, what consideration has been given to the effect on the residents and businesses surrounding the Park, and what mitigations are being proposed?

Overall traffic problem in Golden Gate Park

Parking is a part of the larger problem caused by the massive traffic influx into GGP with the opening of the new museums. We encourage RPD to continue to be proactive in dealing with this problem. There will be even greater numbers of people attracted to the Park in the future. For example, the King Tut exhibit will return to the deYoung in Spring, 2009, with open hours from 9 a.m. to 9 p.m. The next GGP Benefit Concert may draw 80,000 people daily and will overlap with the King Tut exhibit. All of the concert events, daily activities, and museum attendance should be seen as an organic whole for transportation planning.

We hope that an increased effort will be made to attract the general public to transit. The Culture Shuttle and the Intra-Park Shuttle are both good efforts in this direction and need to be supported. Low cost, reliable, frequent, well-publicized, and clearly-labeled public transit will make the Park more accessible for those who cannot or will not drive. With an overall goal of decreasing the number of cars that come to the Park, we can hope that Golden Gate Park will be able to return to the sylvan landscape that it is meant to be.

Thank you for your consideration.

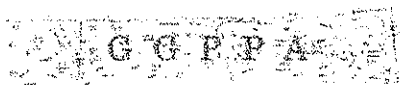

Golden Gate Park Preservation Alliance

Steering Committee

Steering Committee

[Home](#)

[Article - History of Golden Gate Park](#)

[Article Part I: Since When is Land in San Francisco Free?](#)

[Article Part II and Resolution](#)

[Getting Involved](#)

[Steering Committee](#)

[Links to News Articles and Other Information](#)

[Charging for Parking in Golden Gate Park](#)

Our Steering Committee members have worked with the following groups (listed for identification only):

Arthur Chang

- Friends of Washington Square
- Neighborhood Parks Council (Steering Committee / Executive Committee)
- Joe DiMaggio Playground
- Former Vice Chair, PROSAC
- Former Vice Chair, S.F. Common Cause
- NEWAG/FSHWAG Port CAC Development Committee
- Vice President, San Francisco Tomorrow
- Founding Member, Saint Francis Piazza Development Committee
- Former Officer and Board Member, Telegraph Hill Dwellers

Katherine Howard, ASLA

- Co-Chair, Friends of the Music Concourse
- Co-Chair, Park Rangers Coalition
- Chair-elect, Citizens Advisory Committee to the Golden Gate Park Concourse Authority
- Guest Lecturer, Historic Garden Design, UC Berkeley Ext. Cert. Program in Landscape Architecture
- Member, ASLA Historic Preservation Professional Practice Group
- Member, Open Space Committee, Coalition for San Francisco Neighborhoods
- Former Chair, SPUR Sustainable Development Committee
- Former Board Member, PAR (Planning Association for the Richmond)
- Landscape Architect

Margaret Mori, FASLA, IFLA

- Past Chair, American Society of Landscape Architects, Historic Preservation Professional Practice Group
- HALS West-Coast Historic Site Group
- Owner of a Landscape Design/Build practice

Nancy Wuerfel

- Vice Chair, PROSAC (Parks, Recreation, Open Space, Advisory Committee)
- Chair, Open Space Committee, Coalition for San Francisco Neighborhoods
- Board Member, SPEAK, Sunset Parkside Education and Action Committee
- Founder, Parkside 4 Kids (to build the Dianne Feinstein Elementary School)

[Click here to send us an e-mail](#)

Please get in touch to offer comments and join our mailing list. Contact us at:
415 - 731 - 6432

e-mail: ggppa@earthlink.net
snail mail: 717 9th Avenue, San Francisco, CA 94118

Name, logo, and content copyright 2008. GGPPA, k. howard

Last updated on Monday, June 15, 2009 4:42:37 PM

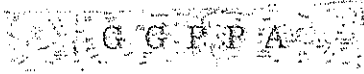

Golden Gate Park Preservation Alliance

"Destroy a public building and it can be rebuilt in a year; destroy a city woodland park and all the people living at the time will have passed away before its restoration can be effected."

William Hammond Hall, Surveyor
First Superintendent of Golden Gate Park

Mission Statement

Ever since its creation in the 1800's Golden Gate Park has been a treasured landscape for all San Franciscans. Since that time, there have been many threats to its continuing as open space. In a time of decreasing open space and increasing population and economic pressures, it is vital that Golden Gate Park be preserved for future generations.

GGPPA is a newly formed group of park activists who are dedicated to preserving the heritage of open space that is Golden Gate Park, so that all San Franciscans can enjoy, now and in the future, this irreplaceable sylvan landscape.

Current Goals

- Preserve the Park as a space which the citizens of San Francisco can enjoy primarily as a sylvan retreat.
- Support the vision for Golden Gate Park as described in the Golden Gate Park Master Plan¹.
- Preserve the historic character of Golden Gate Park as described in the nomination form for the National Register of Historic Sites.²
- Support the City's General Plan which states that new recreation and cultural buildings should be located outside of existing parks and playgrounds.³
- Provide a voice for citizens who are concerned about having an open public process for any proposals for the use of Park land.
- Protect the Park's natural environment from over-use by events that attract massive crowds. Currently, GGPPA is sitting on the RPD advisory committees for the Outside Lands Concert and have been instrumental in including protection for the major trees and other landscape in the planning for that event.
- Resist pressures from forces that view the Park as primarily a revenue generator.
- Ensure that revenues generated by the Park are used to benefit the Park.
- Advocate for increased gardener staff and funding to repair and maintain the Park infrastructure.

We look forward to working with the Department of Recreation and Park in accomplishing these goals and offer our support in these efforts.

¹ *Golden Gate Park Master Plan*, SF Department of Recreation and Park, 1998

² *National Register Historic Site Nomination Form*, Department of Recreation and Park, 2004

³ *San Francisco General Plan*, Policy 2.2, Recreation and Open Space Element

RECEIVED
BOARD OF SUPERVISORS
SAN FRANCISCO

Date: July 13, 2009
To: Clerk of the Board of Supervisors
From: San Francisco Public Library-Finance Department
Subject: Annual Report on Gifts Received up to \$10,000.00

2009 JUL 15 PM 2:42

BY RC

In accordance with Administrative Code Section 10.100-305, this memo serves to provide the Board of Supervisors with a report on gifts up to \$10,000.00 received by the Department during the past FY08-09.

Please find attached report for your reference and usage.

Sincerely,

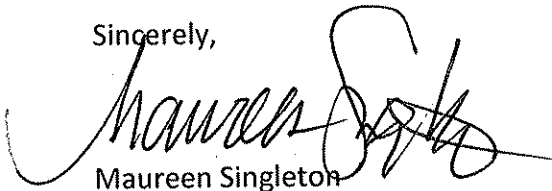

Maureen Singleton
Acting Chief Financial Officer

cc: File, SFPL-Finance Department

12

**SAN FRANCISCO PUBLIC LIBRARY DEPARTMENT
GIFTS TO THE CITY AND COUNTY OF SAN FRANCISCO
REPORT TO THE BOARD OF SUPERVISORS
FISCAL YEAR 2008-09**

The Department received the following gifts during the fiscal year:

Date received by the City	Donor's Name	Donor's financial interest involving City, if any	Nature of Gift	Estimated Value	Use of gift by City
07/17/08	Sunny St Pierre	none	check	100.00	Branch-Glen Park
07/17/08	St. John's Parish Elementary School	not available	check	4,750.00	Branch-Glen Park
09/24/08	Myra B. Freisinger	none	check	25.00	System-wide
10/09/08	Amy Cunninghis & Karen Golinski	none	check	50.00	Branch-Sally Brunn Noe Valley
12/29/08	DW von Kleckner	none	cash	30.00	System-wide
01/08/09	Millersville University	not available	check	100.00	System-wide
01/08/09	Betty L. Hempstead	not available	check	100.00	Main-Library on Wheels
01/15/09	Sasha Price/United Way of New York City	none	check	28.40	System-wide
02/26/09	Info USA	not available	check	100.00	System-wide
02/27/09	SEIU Local 1021	not available	check	2,500.00	System-wide-Juvenile Justice Center Study Hall Program
02/13/09	Vincenza Scarpaci	none	check	25.00	Branch-North Beach (Adult Material)
4/30/2009	Colla Voce Music	none	check	6.87	Main-African-American Center
5/8/2009	Bob Industries/Subaru #9045/Anchor Brewing	not available	cash	300.00	Branch-Potrero Hill

File # 090870
BOS-11

RECEIVED
BOARD OF SUPERVISORS
SAN FRANCISCO

To: Clerk of San Francisco Board of Supervisors

2009 JUL 17 AM 10:53

From: Sam Sirhed,

San Francisco CA 94102

BY MS

RE: Opposing "Greater Union Square Business Improvement District"

This letter is opposition to the formation of the Greater Union Square Business Improvement District(BID). I own the building and the business at 222 Powell St in San Francisco. I am against the proposed BID for many reasons. First, I believe it is very inappropriate to assess another type of tax on property owners in such hard economic times. Business is down all over Union Square 30% or more, you can ask any business owner in my neighborhood. Often times, these BID administrative costs eat up all the money, so how effective will it actually be? Adding one off duty police officer to cover 27 blocks is a far reach from what we actually need. If the BID runs as effectively as the city of San Francisco, we will be running at a deficit. Also, this BID will not stop aggressive panhandling, which is a the biggest problem around Union Square. Tourists complain about homeless and panhandling non-stop, this assessment will not stop them. This assessment will not stop people urinating on my building and sidewalk. We clean up in front of our building everyday, why do I need to pay for someone else who is assigned to do that.

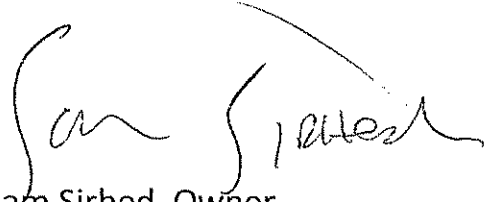

Sam Sirhed, Owner

San Francisco, CA 94102

13

orig: GJ, BOS-11, Cpage
File 090631



CITY AND COUNTY OF SAN FRANCISCO
OFFICE OF THE CONTROLLER

Ben Rosenfield
Controller

Monique Zmuda
Deputy Controller

RECEIVED
BOARD OF SUPERVISORS
SAN FRANCISCO
2009 JUL 16 AM 9:42
MS

July 15, 2009

Ms. Angela Calvillo
Clerk of the Board of Supervisors
1 Dr. Carlton B. Goodlett Place Room 244
San Francisco, CA 94102-4689

RE: **File 090631** – Ordinance allowing the Recreation and Park Department to enter into a naming agreement for the City-owned sports stadium located at Candlestick Point

Dear Ms. Calvillo,

Should this ordinance be approved, in my opinion, it would not in and of itself affect the cost of government and could result in additional revenue for the City.

The proposed ordinance amends the Administrative Code to allow the Recreation and Park Department to approve or enter into an agreement for the naming rights of the City-owned sports stadium located at Candlestick Point. The San Francisco 49ers currently have exclusive rights to sell and enter into agreements with five named entities listed in their 2004 naming agreement with the City. The proposed ordinance would permit the 49ers to enter into agreements with any other naming rights sponsor with prior approval from the Recreation and Park Department and Board of Supervisors.

The City has not earned naming rights revenue from the stadium since 2008. The previous naming rights agreement generated approximately \$700,000 annually for the City. The proposed ordinance could earn revenue for the City by significantly widening the pool of potential naming rights sponsors.

The proposed ordinance also specifies that at least fifty percent of the revenue received by the City from naming agreements shall be used to fund recreation center directors. However, any revenues generated from a naming rights agreement are General Fund revenues and could be used for any legal purposes of the City, subject to Board of Supervisor appropriation approval.

Sincerely,

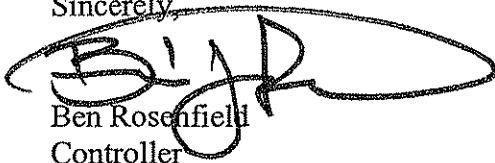
Ben Rosenfield
Controller

Note: This analysis reflects our understanding of the proposal as of the date shown. At times further information is provided to us which may result in revisions being made to this analysis before the final Controller's statement appears in the Voter Information Pamphlet.

14

**Board of
Supervisors/BOS/SFGOV**

07/14/2009 11:09 AM

To BOS Constituent Mail Distribution,
cc
bcc
Subject Fw: Department of Building Inspection Dimensional
Tolerance Policy

Complete a Board of Supervisors Customer Satisfaction form by clicking the link below.
http://www.sfgov.org/site/bdsupvrs_form.asp?id=18548

----- Forwarded by Board of Supervisors/BOS/SFGOV on 07/14/2009 11:12 AM -----

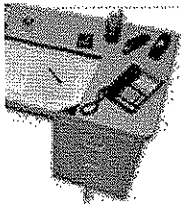

Carolyn Jayin/DBI/SFGOV

07/13/2009 01:13 PM

To "Richard Skaff" <richardskaff
cc board.of.supervisors@sfgov.org, "Thorman, David"
<David.Thorman@dgs.ca.gov>, "Gavin Newsom"
<Gavin.Newsom@sfgov.org>, janet.l.blizard@usdoj.gov,
louis.verdugo@doj.ca.gov, "Conrad, Richard"
<Richard.Conrad@dgs.ca.gov>, Susan
Mizner/ADMSVC/SFGOV@SFGOV, Laurence M.
Kornfield/DBI/SFGOV@SFGOV
Subject Re: FW: Department of Building Inspection Dimensional
Tolerance Policy

Mr. Skaff:

Please see attached letter that was mailed to you back in January responding to your letter.



Skaff Response DBI Dimensional Tolerance Policy.pdf

Carolyn Jayin
Executive Secretary to the Director
Department of Building Inspection
1660 Mission Street, 6th Floor
San Francisco CA 94103
415-558-6131 Phone
415-558-6225 Fax
Email: Carolyn.Jayin@sfgov.org
Web: www.sfgov.org/dbi
"Richard Skaff" <richardskaff@att.net>



"Richard Skaff"

07/06/2009 06:56 PM

To "Carolyn Jayin" <Carolyn.Jayin@sfgov.org>
cc <louis.verdugo@doj.ca.gov>, <janet.l.blizard@usdoj.gov>,
"Gavin Newsom" <Gavin.Newsom@sfgov.org>,
<board.of.supervisors@sfgov.org>,
<susan.mizner@sfgov.org>, "Thorman, David"
<David.Thorman@dgs.ca.gov>, "Conrad, Richard"
<Richard.Conrad@dgs.ca.gov>
Subject FW: Department of Building Inspection Dimensional

15



Tolerance Policy

7/6/09

Carolyn Jayin
Executive Secretary to the Director
Department of Building Inspection
1660 Mission Street, 6th Floor
San Francisco CA 94103

Ms. Jayin,

Has my correspondence (see attached below) to the San Francisco Department of Building Inspection regarding your Dimensional Tolerance Policy been lost? My concerns have clearly been relayed to the Department for quite some time with no acceptable response.

I look forward to a timely response from the Director.

Thank you.

Richard Skaff, Executive Director
Designing Accessible Communities
P.O. Box 2579
Mill Valley, CA 94942
Voice/fax: 415-388-7206
Email: richardskaff@designingaccessiblecommunities.org
Web: www.designingaccessiblecommunities.org

CONFIDENTIALITY NOTICE

The information contained in this e-mail message and any attachments it contains, are intended only for the individual(s) to whom it is addressed and may contain information that is legally privileged, confidential, proprietary, or otherwise not allowed to be disclosed under applicable law. If you are not the intended recipient, any disclosure, copying, or distribution is strictly prohibited and may be unlawful. If you have received this e-mail in error, please notify me immediately by replying to this message and then permanently deleting the original email.

-----Original Message-----

From: Richard [mailto:richardskaff@att.net]
Sent: Friday, January 09, 2009 3:40 PM
To: 'Carolyn Jayin'
Cc: 'Gavin Newsom'; 'board.of.supervisors@sfgov.org';
'susan.mizner@sfgov.org'; 'louis.verdugo@doj.ca.gov';
'janet.l.blizard@usdoj.gov'; 'Thorman, David'; 'Conrad, Richard'
Subject: RE: Department of Building Inspection Dimensional Tolerance Policy

1/9/09

Carolyn Jayin
Executive Secretary to the Director
Department of Building Inspection
1660 Mission Street, 6th Floor
San Francisco CA 94103

Ms. Jayin,

Thank you for your email.

Although I appreciate your email update, I'm quite concerned that I'm only now receiving a response from the San Francisco Building Department to my December 18, 2008 email. I do expect that the Department's response will be forthcoming soon, hopefully within the next ten business days.

Richard Skaff

-----Original Message-----

From: Carolyn Jayin [mailto:Carolyn.Jayin@sfgov.org]

Sent: Friday, January 09, 2009 9:34 AM

To: richardskaff

Subject: Re: Department of Building Inspection Dimensional Tolerance Policy

Mr. Skaff,

We are in receipt of your emails to Acting Director Vivian Day. Staff is in the process of reviewing your request, and will contact you upon completion of their review.

Thank you for bringing this matter to our attention.

Carolyn Jayin
Executive Secretary to the Director
Department of Building Inspection
1660 Mission Street, 6th Floor
San Francisco CA 94103
415-558-6131 Phone
415-558-6225 Fax
Email: Carolyn.Jayin@sfgov.org
Web: www.sfgov.org/dbi

----- Forwarded by Vivian Day/DBI/SFGOV on 01/09/2009 09:28 AM -----

"Richard"
<richardskaff

12/31/2008 02:34
PM

"Vivian Day"
<Vivian.Day@sfgov.org>

To

<susan.mizner@sfgov.org>, "Gavin
Newsom" <Gavin.Newsom@sfgov.org>,
<board.of.supervisors@sfgov.org>,
<louis.verdugo@doj.ca.gov>,
<janet.l.blizard@usdoj.gov>

cc

Subject

FW: Department of Building
Inspection Dimensional Tolerance
Policy

12/31/08

Ms. Vivian Day, Acting Director
San Francisco Department of Building Inspection 1660 Mission Street San
Francisco, CA 94103

Ms. Day,

I am re-sending you the attached email since I have not as yet had a
response from you.

Also, in reviewing the Department's web site, I found that your web staff
directory appears to only available in PDF format and nowhere in that
document could I find the name of the Department's ADA Coordinator.

I look forward to your timely response to both emails.

Thank you.

Richard Skaff

From: Richard Skaff [mailto:richardskaff]
Sent: Thursday, December 18, 2008 5:27 PM
To: Vivian.Day@sfgov.org
Cc: 'Gavin Newsom'; 'board.of.supervisors@sfgov.org';
'susan.mizner@sfgov.org'; 'louis.verdugo@doj.ca.gov'; 'Thorman, David';
'Conrad, Richard'; 'janet.l.blizard@usdoj.gov'
Subject: Department of Building Inspection Dimensional Tolerance Policy

12/18/08

Vivian L. Day, Acting Director
Department of Building Inspection
City and County of San Francisco
1650 Mission Street, 6th Floor
San Francisco, CA 94103

Ms. Day,

I am writing to ask that you take the action to immediately remove the San
Francisco Department of Building Inspection policy titled "Dimensional
Tolerances for New and Existing Construction".

Although the Department's policy may not be as extreme in its
interpretations as the "Reasonable Construction Tolerances for Disable
Access Construction" policy created by the Orange Empire Chapter of ICC
policy (see attached), it is my opinion that many of the assumptions within
your Department's policy are similarly problematic in that I believe they
directly conflict with California Building Code, Title 24 and its intent, to
assure accessibility within the built environment. In 2002, the Attorney
General informed the Orange Empire Chapter that their policy was in conflict
with California Building Code and regulations(see attached letter). In your

Department's tolerance policy, the items listed as "t" through "bb" clearly state that there are no "reference" available to support such tolerances yet the policy supports their use.

During my tenure with the City of San Francisco, when this policy was being discussed at a number of public meetings held by Building Department staff, I clearly stated my opinion, the same opinion that I have today. It is my opinion that the Department of Building Inspection's Construction Tolerance policy is an "underground regulation" and illegal. I felt then as now, that this policy is in violation of state building code and state regulations protecting the rights of persons with disabilities.

Additionally, I am very concerned that the policy was updated by your staff in January, 2008. Was the process used to update the policy carried out in a public forum with input sought from the disability community including the Mayor's Office on Disability and the Mayor's Disability Council? Was the policy and its most recent update reviewed and agreed to by the California Department of Justice, the State Architect's Office and/or the California Building Standards Commission?

I look forward to your timely response.

Richard Skaff

Mill Valley, CA 94941 [attachment "City of San Francisco Construction Tolerance Policy-September 16-1998-Updated-01-01-08.pdf" deleted by Carolyn Jayin/DBI/SFGOV] [attachment "California Attorney General Letters re Orange Empire ICC Construction Tolerance Policy.pdf" deleted by Carolyn Jayin/DBI/SFGOV] [attachment "Construction Tolerances - Orange Empire Chapter of ICBO-Ron Mincer.pdf" deleted by Carolyn Jayin/DBI/SFGOV]

From: Richard Skaff [mailto:richardskaff]

Sent: Thursday, October 25, 2007 8:20 PM

To: 'Isam Hasenin (isam.haenin@sfgov.org)'

Cc: 'louis.verdugo@doj.ca.gov'; 'Baker, Kevin'; Gloria Ochoa (Gloria.Ochoa@sen.ca.gov); 'david.thorman@dgs.ca.gov';

'Richard.Conrad@dgs.ca.gov'; 'lozanoe@csus.edu'; 'Gavin Newsom'; 'board.of.supervisors@sfgov.org'

Subject: San Francisco Department of Building Inspection - Administrative Bulletin AB-014 - Dimensional Tolerances for New and Existing Construction

10/25/07

Mr. Isam Hasenin, Director
Department of Building Inspection
1660 Mission Street
San Francisco, California 94103

Mr. Hasenin,

It was a pleasure seeing you at the Board of Supervisors Land Use Committee meeting this week. I hope you are finding your new position with the City of San Francisco a positive, interesting and challenging experience.

As I stated during our brief "hello" at the hearing, I was surprised by the agenda item regarding the Board of Supervisors adoption of the 2007

California Building Code. My question about the agenda item was whether the Department of Building Inspection (DBI) was asking the Board to support any local changes or additions to the recently adopted State Building Code, Title 24 access codes for persons with disabilities. I was pleased to be assured by you and Mr. Kornfield that no changes to the 2007 California Building Code access sections were being proposed by DBI.

Today, I visited your Department's web site. I would like to inform you that although your web site must be accessible to everyone, including those visitors who are blind and using a screen reading program, your site has photos, called "jpgs", and at least one of the photos on your Department's home page appears to have no backup written description to assure that a screen reading program used by a blind visitor would be able to "see" what the photo visually describes to a sighted visitor. Another of your site's pages, showing the Department's "GIS Permit Tracking Application" appears to be completely inaccessible to persons who are blind. Although I understand that the program used for that page is dynamic so that individuals can actually see satellite photos of building sites throughout the City, I would think that there could be an alternate format available for those visitors whose software can't function with the GIS tracking system.

While visiting your Department's site, I took the time to review the section titled "Administrative Bulletins" and was surprised to find one of the Department's bulletins, AB-014, that I apparently wasn't aware of in 1999 when it appears to have been prepared and then approved by Mr. Kornfield ("Update reviewed by Laurence M. Kornfield, Chief Building Inspector, DBI, Technical Services Division, May 21, 1999"). I was surprised because I remember that during my tenure as a City employee, there was an attempt by the Department to adopt a similar Construction Tolerance Bulletin. At that time it was my understanding (obviously an incorrect understanding) that the Department had made the decision to not go forward with the adoption of a Bulletin allowing construction tolerances.

I have attached a copy of the California Attorney General's letter to the Orange Empire ICC Chapter regarding its' policy on construction tolerances. It would be my hope that after reviewing the letter from the California Department of Justice, you and the Building Department's Commission would reconsider Administrative Bulletin AB-014 and make the right decision to strike it from your list of Administrative Bulletins. It is my belief that this document creates an "underground" regulation that is not only inappropriate but, I believe, illegal. I'm not only surprised but disappointed that the City would allow such a policy to be created and hope that as the newly appointed Director, you will correct that mistake.

I look forward to your timely response to the issues I have raised in this email and thank you in advance for your consideration of my request.

Richard Skaff, Executive Director
Designing Accessible Communities

Mill Valley, Ca. 94942

CONFIDENTIALITY NOTICE

The information contained in this e-mail message and any attachments it contains, are intended only for the individual(s) to whom it is addressed



January 26, 2009

**Administrative Bulletin AB-014 -
Dimensional Tolerances for New and
Existing Construction**

Mr. Richard Skaff

Mill Valley, California 94941

Dear Mr. Skaff:

Thank you for your email about **Administrative Bulletin AB-014, Dimensional Tolerances for New and Existing Construction**. This bulletin was developed to allow proper implementation of regulations adopted by the California Building Standards Commission. Those regulations, subjecting construction and manufacturing tolerances to "conventional industry tolerances, except where the requirement is stated as a range with specific minimum and maximum end points" may currently be found in California Building Code Section 1101B.5.

After careful evaluation of the Administrative Bulletin development records, processes, and discussions with the Department of Building Inspection personnel, we have confirmed that this bulletin was properly developed, adopted and implemented. The provisions of this bulletin have been applied since November 12, 1998.

The adoption process under which Administrative Bulletin AB-014 had been subjected included extensive public review and comment, along with the review and approval by five separate San Francisco commissions/ committees; namely, the Building Inspection Commission, the Access Appeals Commission, the Code Advisory Committee, the Disability Access Advisory Committee, and the Subcommittee on Construction Tolerances.

Components of **Administrative Bulletin AB-014** that did not reference national standards or other published standards were developed by the Subcommittee on Construction Tolerances based on information available, including testimonies of construction experts, persons with disabilities, and other input. On at least one occasion, construction conditions were mocked-up to allow a better understanding of the effects on users of various tolerances. Please note that no tolerance in this bulletin exceeds ½ inch, with most tolerances substantially less.

Since their adoptions in 1998, updates to Administrative Bulletin AB-014 were made to properly reflect changes in the adopted, underlying codes, without altering the substantive tolerances. Such changes to Administrative Bulletins are made administratively by the Department of Building Inspection.

We have referred your correspondence expressing your concerns, along with copies of this letter and the current **Administrative Bulletin AB-014**, to the Code Advisory Committee and to the Access Appeals Commission for further consideration. Inasmuch as all commissions and committees in the City and County of San Francisco have a period for public comment on any topic, you may wish to personally address your concerns at those times.

For your information, attached is a chronology of the development of **Administrative Bulletin AB-014, Dimensional Tolerances for New and Existing Construction**.

Thank you for sharing your concerns about this matter.

Very truly yours,

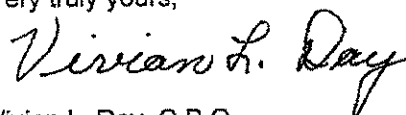

Vivian L. Day, C.B.O.
Acting Director

Attachment: Chronology of the Development of Administrative Bulletin AB-014
Copy of R. Skaff's letter sent by email
Administrative Bulletin AB-014

cc: Hon. Mayor Gavin Newsom, CCSF
The Board of Supervisors, CCSF
Code Advisory Committee
Access Appeals Commission
Ms. Susan Mizner, SF Mayor's Office
Mr. Louis Verdugo, CA DOJ
Ms. Janet L. Blizard, US DOJ
Mr. David Thorman, CA DGS
Mr. Richard Conrad, CA DGS

VLD/LK/ce
Letter - Richard Skaff

cc: Director's Office File

**Chronology of the Development of
ADMINISTRATIVE BULLETING AB-014:
Dimensional Tolerances for New and Existing Construction**

- **January 29, 1997.** Memorandum from DBI Deputy Director William Wong regarding proposed California Building Code revision to add Section 1101B.4 to subject construction to conventional building industry tolerances, requesting written comments.
- **February 5, 1997.** Letter to the California Building Standards Commission from Deputy Director Jim Hutchinson, supporting the adoption of a revision to the California Building Code to allow the use of conventional building tolerances and construction.
- **April 2, 1997.** Hearing at the Building Inspection Commission (BIC) and presentation by Deputy Director Hutchinson regarding proposed California Building Code about construction tolerances. Request by the Commission to convene a working group and to provide broad notice to allow members representing many interests to discuss this matter.
- **April 3, 1997.** Memorandum from DBI Deputy Director William Wong directing Chief Building Inspector Kornfield to create a subcommittee and to include representation of interested parties.
- **April 4, 1997.** Minutes of the DBI's Disability Access Advisory Committee on discussion on Construction Tolerances and meeting scheduling. Other issues related to disability access and construction tolerances are also noted in these minutes.
- **April 17, 1997.** Correspondence from BOMA and from Huntsman Architectural Group regarding interest in construction tolerance topics.
- **April 22, 1997.** Meeting of the Construction Tolerances Subcommittee of the Disability Access Advisory Committee at which items were discussed including: critical design and construction issues, concepts to be followed, consideration of standards to be applied.
- **June 4, 1997.** Meeting minutes of the Construction Tolerances Subcommittee of the Disability Access Advisory Committee about acceptability of implementing a construction tolerance Administrative Bulletin, meaning of construction tolerance, and related topics. Draft standards excerpted from various standard references provided by DBI staff.
- **July 2, 1997.** Meeting of the Construction Tolerances Subcommittee of the Disability Access Advisory Committee. General discussion about related issues.
- **July 2, 1997.** Correspondence from CALFOX, Inc. supporting development of reasonable construction tolerances.
- **July 2, 1997.** Request from Walter Park that minutes be revised to accurately reflect discussion.
- **July 8 1997.** Correspondence from BOMA re: appropriateness of developing acceptable construction tolerance regulations based on research by Mr. Lawrence Perry, BOMA code consultant.

- **July 24, 1997.** Letter to Mr. Walter Park from Chief Building Inspector Kornfield regarding the content of minutes of meetings.
- **August 6, 1997.** Meeting of the Construction Tolerances Subcommittee of the Disability Access Advisory Committee. Continued discussion of issues related to acceptable construction tolerances.
- **August 15, 1997.** Update to the Disability Access Advisory Committee regarding progress by the Construction Tolerances Subcommittee of the Disability Access Advisory Committee in the development of an Administrative Bulletin.
- **September 3, 1997.** Meeting of the Construction Tolerances Subcommittee of the Disability Access Advisory Committee on issues related to acceptable construction tolerances. Note that as of January 1998, DBI would begin enforcing construction tolerances in accordance with California Building Code requirements.
- **October 1, 1997.** Meeting of the Construction Tolerances Subcommittee of the Disability Access Advisory Committee canceled due to lack of attendance.
- **November 5, 1997.** Meeting of the Construction Tolerances Subcommittee of the Disability Access Advisory Committee where **Administrative Bulletin Draft #1** developed and reviewed.
- **December 3, 1997.** Meeting of the Construction Tolerances Subcommittee of the Disability Access Advisory Committee. Continued development of an Administrative Bulletin. **Administrative Bulletin Draft #2** reviewed.
- **February 20, 1998.** Meeting of the Construction Tolerances Subcommittee of the Disability Access Advisory Committee, **Administrative Bulletin Draft #3** reviewed.
- **March 5, 1998.** Request for general public comment on **Administrative Bulletin Draft #3**. Request sent to city agencies, boards and commissions, professional societies and organizations, building owners' representatives, and other persons.
- **March 9, 1998.** Memorandum from Todd Huntington, Residential Plan Check Manager, supporting the draft administrative bulletin.
- **March 18, 1998.** Update on progress toward developing this Administrative Bulletin before the Building Inspection Commission.
- **April 9, 1998.** Comments received from Richard Skaff, DPW Disability Access Coordinator, regarding the proposed Administrative Bulletin.
- **April 27, 1998.** Hearing on this bulletin before the Access Appeals Commission. General discussion, with a comment of about the development of this bulletin by Commissioner Walter Park.
- **May 8, 1998.** Memorandum from Carla Johnson, Building Inspector, commenting and expressing consensus on proposed Administrative Bulletin.
- **May 11, 1998.** Memorandum from Richard Skaff, DPW Disability Access Coordinator, transmitting comments from the Department of Public Works regarding dimensional tolerance issues.

- **May 11, 1998.** Letter from Harry Wong, Architect with Asian Neighborhood Design, regarding the dimensional tolerances Administrative Bulletin and requesting broadening provisions for existing conditions.
- **May 12, 1998.** Memorandum from William Wong, Deputy Director, approving an extension of the period for submittal of comments on this draft administrative until June 11, 1998 at the request of Mr. Richard Skaff.
- **June 8, 1998.** Memorandum from Mr. Richard Skaff regarding changes to the California Building Code, effective April 1, 1998.
- **June 20, 1998.** Letter from the Lurie Company regarding the proposed administrative bulletin.
- **June 30, 1998.** Memo from Wing Lau of the Bureau of Building Inspection regarding the proposed construction tolerance policies.
- **July 3, 1998.** Letter from Bruce Bonacker, architect, representing the National Association of the Remodeling Industry, in support of the proposed Administrative Bulletin.
- **July 17, 1998.** Letter from Douglas G. Tom, AIA, representing the American Institute of Architects, San Francisco Codes Committee and Board of Directors, supporting the development of the construction tolerances bulletin and finding that this bulletin will "bring San Francisco into conformance with the requirements of the State of California and the US Department of Justice for dealing with construction tolerances."
- **July 22, 1998.** Letter from Ken Cleveland, Director of Governmental Affairs for the Building Owners and Managers Association of San Francisco, supporting the adoption of the Administrative Bulletin regarding construction tolerances.
- **August 14, 1998.** Summary of comments received from over 15 reviewers regarding Administrative Bulletin Draft #3, including notes regarding proposed revision actions taken by DBI in response to these comments. Preparation and distribution of **Administrative Bulletin Draft #4.**
- **August 21, 1998.** Presentation of **Administrative Bulletin Draft #4** to the Disability Access Advisory Committee for public hearing. The Disability Access Advisory Committee recommends the bulletin be forwarded with their unanimous support to the full Code Advisory Committee for recommendation of adoption by the Building Inspection Commission and the Department of Building Inspection.
- **September 1, 1998.** Memorandum issued by Frank Chiu, Director of the Department of Building Inspection, distributing Administrative Bulletin Draft #4 to the general DBI mailing list and other interested parties for final comments.
- **September 11, 1998.** Deadline for final comments on Administrative Bulletin Draft #4.
- **September 16, 1998.** Code Advisory Committee unanimously recommends adoption by the Building Inspection Commission of the Administrative Bulletin regarding construction tolerances.

- **September 16, 1998.** Building Inspection Commission unanimously passes Resolution Number BIC - 082.98 adopting this Administrative Bulletin. Building Inspection Commission President Hood said that "the construction tolerance bulletin was one of the top priorities of the BIC."
- **November 12, 1998.** Administrative Bulletin AP -- 014.98, Dimensional Tolerances for New and Existing Buildings, signed by DBI Director Frank Chiu, and effective this date.
- **May 21, 1999.** Administrative Bulletin AP-014.98 reference was changed to AB-014, Dimensional Tolerances for New and Existing Buildings, and the bulletin was updated for code references to be consistent with the 2001 San Francisco Building Code. No changes were made to allowable tolerances or to any substantive elements.
- **January 1, 2008.** AB-014, Dimensional Tolerances for New and Existing Buildings, was updated for code references to be consistent with the 2007 San Francisco Building Code. No changes were made to allowable tolerances or to any substantive elements.

(received by email)

12/18/08

Vivian L. Day, Acting Director
Department of Building Inspection
City and County of San Francisco
1650 Mission Street, 6th Floor
San Francisco, CA 94103

Ms. Day,

I am writing to ask that you take the action to immediately remove the San Francisco Department of Building Inspection policy titled "Dimensional Tolerances for New and Existing Construction".

Although the Department's policy may not be as extreme in its interpretations as the "Reasonable Construction Tolerances for Disabled Access Construction" policy created by the Orange Empire Chapter of ICC policy (see attached), it is my opinion that many of the assumptions within your Department's policy are similarly problematic in that I believe they directly conflict with California Building Code, Title 24 and its intent, to assure accessibility within the built environment. In 2002, the Attorney General informed the Orange Empire Chapter that their policy was in conflict with California Building Code and regulations (see attached letter). In your Department's tolerance policy, the items listed as "t" through "bb" clearly state that there are no "reference" available to support such tolerances yet the policy supports their use.

During my tenure with the City of San Francisco, when this policy was being discussed at a number of public meetings held by Building Department staff, I clearly stated my opinion, the same opinion that I have today. It is my opinion that the Department of Building Inspection's Construction Tolerance policy is an "underground regulation" and illegal. I felt then as now, that this policy is in violation of state building code and state regulations protecting the rights of persons with disabilities.

Additionally, I am very concerned that the policy was updated by your staff in January, 2008. Was the process used to update the policy carried out in a public forum with input sought from the disability community including the Mayor's Office on Disability and the Mayor's Disability Council? Was the policy and its most recent update reviewed and agreed to by the California Department of Justice, the State Architect's Office and/or the California Building Standards Commission?

I look forward to your timely response.

Richard Skaff

Mill Valley, CA 94941

ADMINISTRATIVE BULLETIN

- AB-014** :
- DATE** : September 16, 1998 (Updated 01/01/08 for code references)
- SUBJECT** : Inspection
- TITLE** : **Dimensional Tolerances for New and Existing Construction**
- PURPOSE** : This bulletin details dimensional tolerances which can be accepted by field inspection personnel from the Department of Building Inspection when reviewing on-site construction work. This bulletin is the procedural implementation of the California Building Code, Section 1101B.4 and 1104B.5, Dimensional Tolerances, which amends the State code to permit jurisdictions to allow dimensional tolerances which meet industry standards. These tolerances should allow construction to proceed with dimensions as shown on the plans or in the code that are not exact but are within the standards accepted by the industry, the Department and the community.
- REFERENCES** : 2007 San Francisco Building Code
- Sections 1101B.4 and 1104B.5 Dimensional Tolerances
2007 San Francisco Plumbing Code
2007 San Francisco Electrical Code
The Handbook of Construction Tolerances, McGraw Hill, 1994, David Kent Ballast, editor.
- DISCUSSION** : The application of dimensional construction tolerances is necessary because structures cannot be built which conform precisely to code defined absolute dimensions without deviation. This bulletin defines the limits of those deviations within which administrative approval can be routinely granted. Any deviations beyond these must be addressed in the form of "unreasonable hardships" through the standard Documentation of Unreasonable Hardship process. These tolerances are based on industry standards for materials and methods of construction and are not intended to approve any incorrect dimensions or design changes. These are not code changes but approvals for variance based on as-built conditions. This applies to both new construction and the remodeling of existing structures.

One of the bases of the Department's construction tolerance standards is the 1994 Edition of the Handbook of Construction Tolerances, edited by David Kent Ballast. This is a commonly used reference book regarding industry standards for tolerances and, as excerpted below, is adopted by this bulletin as representing the standards for tolerances within the City and County of San Francisco. Please note that some adjustments and additions to these tolerances have been made inasmuch as the Handbook of Construction Tolerances does not specifically address disabled access issues. Where specific accessibility conditions needed to be addressed, such standards have been added as needed. Per Section 1101B.4, dimensions that are not stated as "maximum" or "minimum" are absolute. The Department may administratively modify and/or add to the below referenced standards as necessary to meet the intent of the codes.

Standard tolerances will be based upon the nominal manufactured dimensions of fabricated goods.

Note that the State Historical Building Code provides other remedies for variations which may be addressed through the provisions of Administrative Bulletin No. AB-013. This applies to all qualified historic properties. In cases where the State Historical Building Code is applied, that code takes precedence over the regular Building Code requirements.

The following tolerances are to be used:

- a. Concrete paving.
Standard: Plus or minus 1/4" over 10' for drives, parking surfaces, sidewalks and other site paving.
Ref. ACII17-06
- b. Concrete slabs for flatness and straightness.
Standard: Bull-float slab is plus or minus 1/2" over 10'.
Ref. ACII17-06 and ASTM E1155-96
- c. Cast-in-place concrete walls:
Standard: Plumb is 1/4" in 10'.
Ref. ACII17-06
- d. Concrete masonry unit and masonry construction.
Standard: 1/4" in 10' vertical or horizontal
Ref. ACII17-06
- e. Brick wall construction.
Standard: 1/4" in 10' vertical or horizontal
Ref. ACII17-06
- f. Granite and marble installation.
Standard: 1/4" in 10' vertical or horizontal.
Ref. Dimension Stone Design Manual VII, Marble Institute of America, Inc. 2007
- g. Limestone installation.
Standard: 1/4" in 10' vertical or horizontal.
Ref. Various industry standards
- h. Slate tile installation for flooring or walls.
Standard: Vertical or horizontal 1/4" in 10'.
- i. Wood floor framing and sub-flooring.
Standard: 1/4" in 10' horizontal tolerance.
Ref. Spectext, Section 06112, Framing and Sheathing by the Construction Sciences Research Foundation, 2006
- j. Floor and wall tile.
Standard: 1/4" in 8' for wall and flooring. This does not apply to thresholds.
Ref. ANSI A108.1, A108.4, and A108.5

- k. Terrazzo flooring.
Standard: 1/4" in 10'
Ref. Terrazzo Information Guide, the National Terrazzo and Mosaic Association, 1993
- l. Wood flooring.
Standard: 1/4" in 10'
Ref. ANSI/HPMA LHF, 1982
- m. Other stone installation.
Standard: 1/4" in 10'
Ref. Dimensions, Stone Design Manual IV, 1991
- n. Cabinets and counter tops.
Standard: 1/4" in 12' out of parallel with the floor; 1/8" variation in clear width.
Ref. Quality Standards for the Professional Remodeler, Second Edition, National Association of Homebuilders, Remodelers Council, 1991
- o. Flatness of counter tops.
Standard: 1/4" per 8'.
Ref. Architectural Woodwork Quality Standards, Architectural Woodwork Institute, 1993
- p. Storefront installation.
Standard: Storefront systems to be vertical plus or minus 1/8" in 12';
Ref. Aluminum Storefront and Entrance Manual, American Architectural Manufacturers Association, 1987
- q. Framing for gypsum wallboard.
Standard: 1/8" in 10' vertical and horizontal.
Ref. GA-216
- r. Wallboard partitions, ceilings, and trim.
Standard: 1/4" in 10'
Ref. ANSI A108.11, and GA-216
- s. Installation of lath and plaster.
Standard: 1/4" per 10'
Ref. ASTM C926
- t. Clear opening at doors.
Standard: plus or minus 3/8"
Ref. None.
- u. Plumbing fixture installation
Standard: plus or minus 1/2" measured from the finished wall or floor.
Ref. None

- v. Handrail dimensions.
Nominal handrails not to vary more than 3/16" in diameter from code dimension; height plus or minus 3/16" measured from finished floor.
Ref. None.
- w. Threshold.
Standard: 1/8" variation in threshold height is permitted above the finished floor surface.
Ref. None
- x. Knee clearance under wall mounted plumbing fixtures, including lavatories, drinking fountains, urinals and toilets.
Standard: Mounting height above finished floor equals plus or minus 3/8". Within a 30" wide area, centered on the accessible basin or fixture, there may be a variation of 1/4" in height between the lower edge of the counter and the finished floor.
Ref. None
- y. Switches, receptacles, pull stations, controls and similar devices.
Standard: Plus or minus 1/2" vertically.
Ref. None
- z. Door operating pressure.
Standard: Plus or minus 1/2 pound.
Ref. None
- aa. Operating pressures for faucets, flush valves and miscellaneous hardware.
Standard: Plus or minus 1/2 pound.
Ref. None
- bb. Other elements. Other constructed elements which are not specifically regulated shall be permitted to have a construction tolerance of 1/4" plus or minus unless, in the opinion of the district inspector, such variation impedes access, except that grab bars and handrails shall be not more than the maximum horizontal distance from the adjoining wall surface than is permitted by the regular code.

Approved by the Building Inspection Commission on September 16, 1998

Originally signed by:
Frank Y. Chiu, Director
November 12, 1998

BOARD of SUPERVISORS



City Hall
Dr. Carlton B. Goodlett Place, Room 244
San Francisco 94102-4689
Tel. No. 554-5184
Fax No. 554-5163
TDD/TTY No. 544-5227

Date: July 14, 2009

To: Members of the Board of Supervisors

From: Angela Calvillo, Clerk of the Board 

Subject: Form 700

This is to inform you that the following individual has submitted a Form 700 Statement of Economic Interests to my office.

Michael Stover-Fiscal Officer-Leaving

16

City and County of San Francisco

Human Services Agency

Department of Human Services
Department of Aging and Adult Services



Gavin Newsom, Mayor

Trent Rhorer, Executive Director

RECEIVED
BOARD OF SUPERVISORS
SAN FRANCISCO

2009 JUL 15 PM 2:43

AC

Date: Tuesday, July 14, 2009
To: Clerk of the Board of Supervisors
From: Patrick Leung
Subject: FY 08-09 Annual Report on Gifts Received up to \$10,000

In accordance with Administrative Code Section 10.100-305, this memo serves to provide the Board of Supervisors with a report on gifts up to \$10,000 received by the Human Services Agency during the past fiscal year:

<u>Gift Description</u>	<u>Source</u>	<u>Value</u>	<u>Disposition</u>
Volunteer Income Tax Assistance Program	United Way	\$7,000	

Sincerely,

Patrick Leung
Human Services Agency
415-557-5542

17

CITY AND COUNTY OF SAN FRANCISCO RECEIVED OFFICE OF THE TREASURER
BOARD OF SUPERVISORS
SAN FRANCISCO



2009 JUL 13 PM 3:32

José Cisneros
TREASURER

PAULINE MARX
Chief Assistant Treasurer

Newlin Rankin
Chief Investment Officer

Document is available RC
at the Clerk's Office
Room 244, City Hall

July 10, 2009

The Honorable Gavin Newsom
Mayor of San Francisco
City Hall, Room 200
1 Dr. Carlton B. Goodlett Place
San Francisco, Ca 94102-0917

The Honorable Board of Supervisors
City and County of San Francisco
City Hall, Room 244
1 Dr. Carlton B. Goodlett Place
San Francisco, Ca 94102-0917

Ladies and Gentlemen:

This correspondence and its attachments show the investment activity (for fiscal year to date) of the portfolios under Treasurer's management.

Portfolio Statistics from July 1, 2008 to June 30, 2009:

	Pooled	All
Interest Received	\$85,375,579	\$87,495,419
Total Net Earnings	\$76,998,503	\$79,133,572
Earned Income Yield	2.571%	2.562%
Average Age of Portfolio	576 Days	567 Days

Total cost of the securities on hand as of June 30, 2009 was \$3,028,914,501 with a market value of \$3,021,715,113 plus fixed assets accrued interests of \$5,286,914. The earned yield for the month of June 2009 is 3.823%.

In accordance with provisions of California State Government Code Section 53646, we are forwarding herewith computer printouts detailing the City's investment portfolio as of June 30, 2009. These investments are in compliance with California Code and our statement of investment policy, and provide sufficient liquidity to meet expenditure requirements for the next six months.

Very truly yours,

José Cisneros
Treasurer

Enc.

cc: Harvey Rose, Budget Analyst (w/Enc.)
Ben Rosenfield, Controller (w/Enc.)
Controller - Internal Audit Division -YTD-All Funds, YTD-Pooled Funds
Oversight Committee: R. Sullivan, Dr. Don Q. Griffin, J. Grazioli, T. Rydstrom, P. Marx
Transportation Authority - David Murray, San Francisco Public Library - 2 copies
Office Copy

City Hall Rm.140, #1 Dr. Carlton B. Goodlett Place, San Francisco, CA. 94102

(415) 554-4478

18

> AHIMSA PORTER SUMCHAI, M.D.

>
>
>
>
>
>

> From: asumchai
> To: asumchai_
> Subject: Ahimsa Porter Sumchai, M.D. - Medical office photo
> Date: Sat, 21 Feb 2009 14:58:06 -0800

>
>
>
>
>

> From: steve
> To: asumchai
> Subject: Re: Medical office photo's
> Date: Tue, 29 Jan 2008 15:25:58 -0800

> Here you go. As my people say, "use it in good health". :-)

>
>

> Steve

>

> [cid:8CE846AA-E354-4106-A7AC-C4063DE6BED1:
> On Jan 29, 2008, at 2:47 PM, ahimsa sumchai wrote:

>

> Can you send copies of the photos? I will use them with your permission only. I would like to write a piece on single payer health care for the SF Bayview and use some of the shots to promote Cindy's campaign.

>

> Dr. Ahimsa Porter Sumchai NSCA-CPT

>

>

> Shed those extra pounds with MSN and The Biggest Loser! Learn more.<
<http://biggestloser.msn.com/>>

>

>

>

> Get in touch in an instant. Get Windows Live Messenger now.<
http://www.windowslive.com/messenger/overview.html?ocid=TXT_TAGLM_WL_Refresh_getintouch_042008>

>

>

Hotmail® has ever-growing storage! Don't worry about storage limits. [Check it out.](#)



2008-01-18_16-21-48.jpg



Curriculum Vitae, Research & Annotated Bibliography.doc



Flight Crew - Stanford Life Flight.jpg



ROTORCRAFT AEROMEDICAL TRANSPORT.doc

**Board of
Supervisors/BOS/SFGOV**

07/16/2009 11:47 AM

To Sophie Maxwell/BOS/SFGOV, Eric L Mar/BOS/SFGOV,
David Chiu/BOS/SFGOV, Linda Laws/BOS/SFGOV,

cc

bcc

Subject Fw: Stanford Life Flight rooftop helipad per Captain Ev Croes

Complete a Board of Supervisors Customer Satisfaction form by clicking the link below.

http://www.sfgov.org/site/bdsupvrs_form.asp?id=18548

----- Forwarded by Board of Supervisors/BOS/SFGOV on 07/16/2009 11:50 AM -----



"Dr. Ahimsa Sumchai"

07/15/2009 05:08 PM

To Board Supervisors <board_of_supervisors@ci.sf.ca.us>

cc

Subject Stanford Life Flight rooftop helipad per Captain Ev Croes

Submission to Land Use subcommittee hearing on proposed helipad siting at UCSF Mission Bay.

AHIMSA PORTER SUMCHAI, M.D. 

From: asumchai

To: info@planning.ucsf.edu; hospitaleir@planning.ucsf.edu; eir@planning.ucsf.edu;
asumchai

Subject: Stanford Life Flight rooftop helipad per Captain Ev Croes

Date: Wed, 25 Feb 2009 08:10:35 +0800

Dr. Ahimsa Porter Sumchai

Subject: Replacement photos

Date: Fri, 20 Oct 2006 23:05:25 -0600

From: ECroes

To: asumchai

Hi Ahimsa,

20

Here are your SUH helipad photos.











Warm Regards,

Capt. Mhz

Ev.

Chat online and in real-time with friends and family! [Windows Live Messenger](#)

Insert movie times and more without leaving Hotmail®. [See how.](#)  

     
Helipad4.JPG Helipad3.JPG HelipadView.JPG LandingSUH.JPG LifeFlightFromBelowMED.jpg NewPadConnection.JPG
    
StanfordAerial3.JPG NewPadParking.JPG SunsetHelipad2.jpg NewPadWindSock.JPG RAINDAY1SM.jpg



"Dr. Ahimsa Sumchai"

07/16/2009 05:36 PM

To: Mary Ratcliff <editor@sfbayview.com>, Pat Monk
>, Parkside Listserve
<home@prosf.org>, Roland sheppard
cc: Pat Monk <patmonkrn@prosf.org>, Mesha
<communityfirstcoalition@yahoogroups.com>, Bayview
Listserve <enough_bvhp@prosf.org>
bcc:

Subject: Chickens come home to roost! SAVE CANDLESTICK PARK

Like Malcolm X said...chickens always come home to roost. There's nothing remarkable. Everyone "tears their drawers" with Lennar corporation sooner or later...you just have to wait them out. Remember the African American employees who sued. The city and county of San Francisco will get sick and tired of wearing an albatross around their necks named Lennar corporation- one day soon!

AHIMSA PORTER SUMCHAI, M.D.

To: patnlisa@sbcglobal.net
CC: patmonkrn@yahoogroups.com; communityfirstcoalition@yahoogroups.com;
enough_bvhp@yahoogroups.com; isf23@yahoogroups.com; rezurxn@hotmail.com
From: editor@sfbayview.com
Date: Wed, 15 Jul 2009 21:52:38 -0700
Subject: Re: [CommunityFirstCoalition] SAVE CANDLESTICK PARK

I can't believe it! Arc Ecology talking about Lennar like a dog! Wonders never cease!

Maybe it's a little too soon to celebrate a victory, but we sure can claim it - and it took every single one of us to turn the tide.

Mary
SF Bay View

<http://www.youtube.com/watch?v=IB1Jp-kYjOc>

[Messages in this topic \(2\)](#) | [Reply \(via web post\)](#) | [Start a new topic](#)
[Messages](#) | [Files](#) | [Photos](#) | [Links](#) | [Database](#) | [Polls](#) | [Members](#) | [Calendar](#)

21

Ahimsa Porter Sumchai, M.D., NSCA-CPT

San Francisco, California 94127-1423

C-Page
Copies - ea sup. done
fe

7/17/09

To: Mo. Angela Calvillo

Clerk - San Francisco Board of Supervisors

Re: Public Comment

Support of Proposal to site rooftop helipad
UCSF Loren, Children's & Cancer Center
Mission Bay Campus

Ahimsa Porter Sumchai, M.D.

RECEIVED
BOARD OF SUPERVISORS
SAN FRANCISCO

2009 JUL 17 PM 12:11

BY

fe

Sports Medicine and General Practice · Member, American College of Sports Medicine
AAAI/ISMA Certified Nutrition Consultant · Stanford Fellowship Research Consultant
Certified Personal Trainer with NSCA Certification

22

DR. AHIMSA P SUMCHAI
236 W PORTAL AVE #563
SAN FRANCISCO, CA 94127

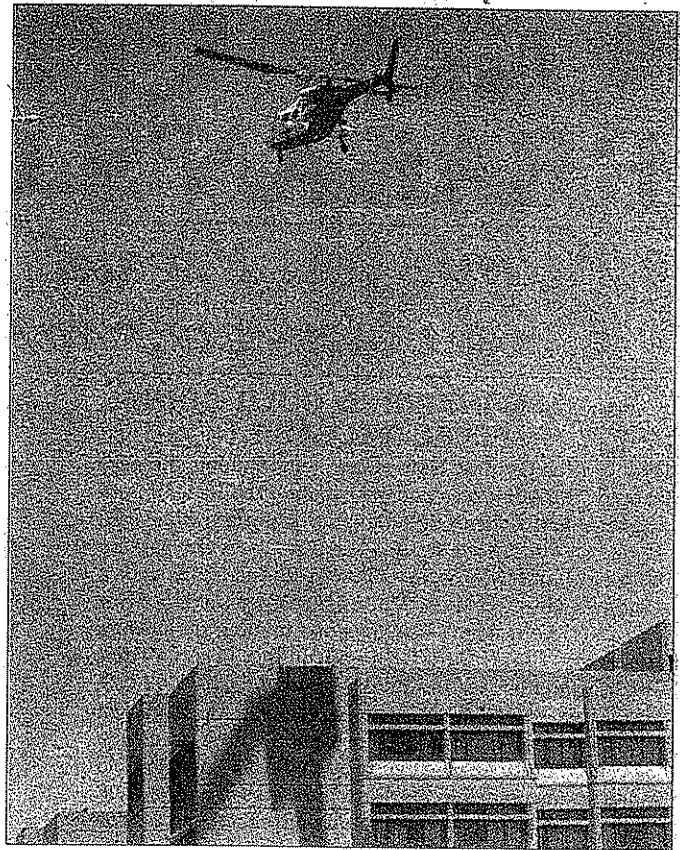
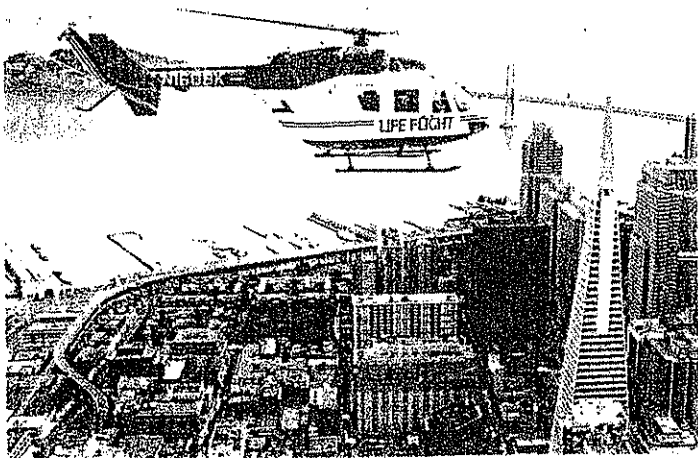
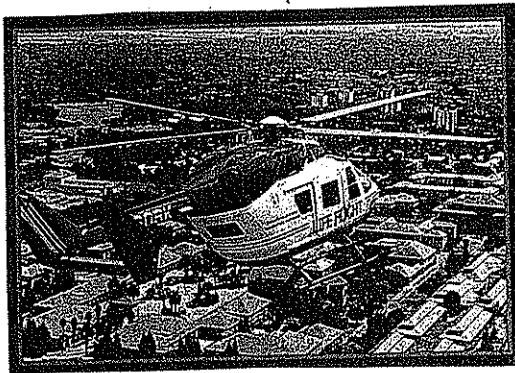
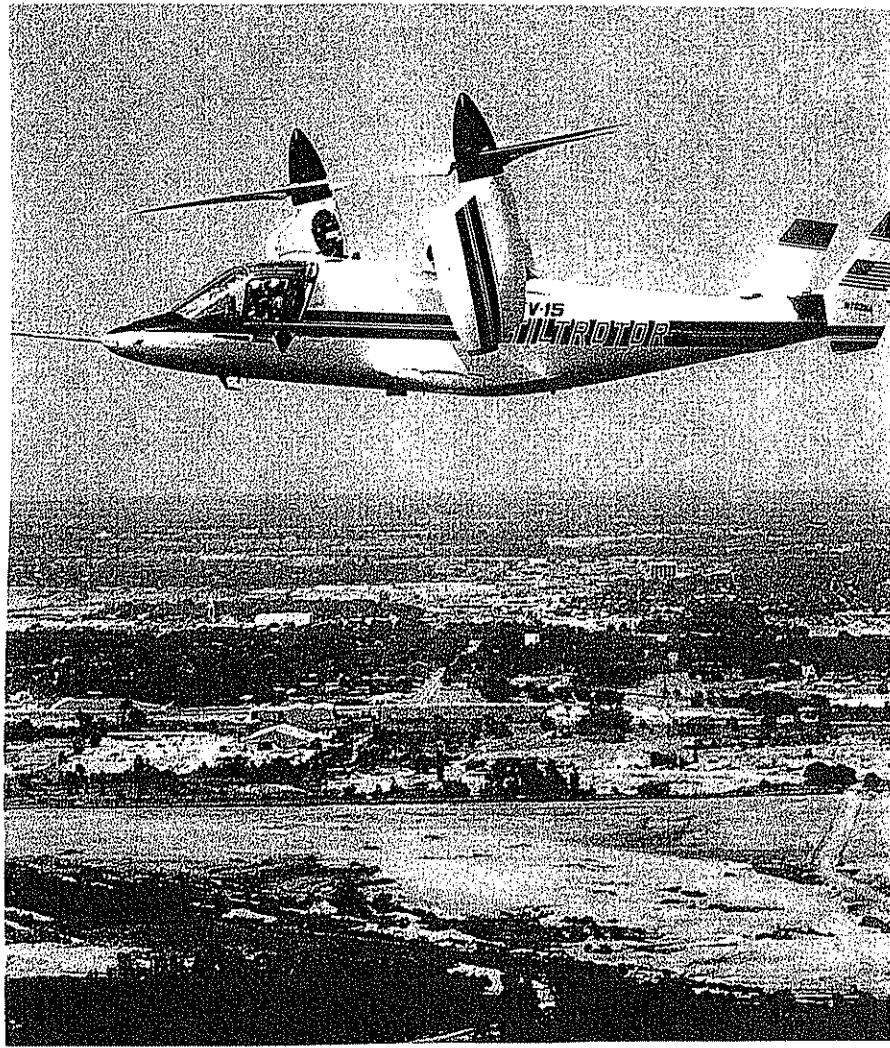

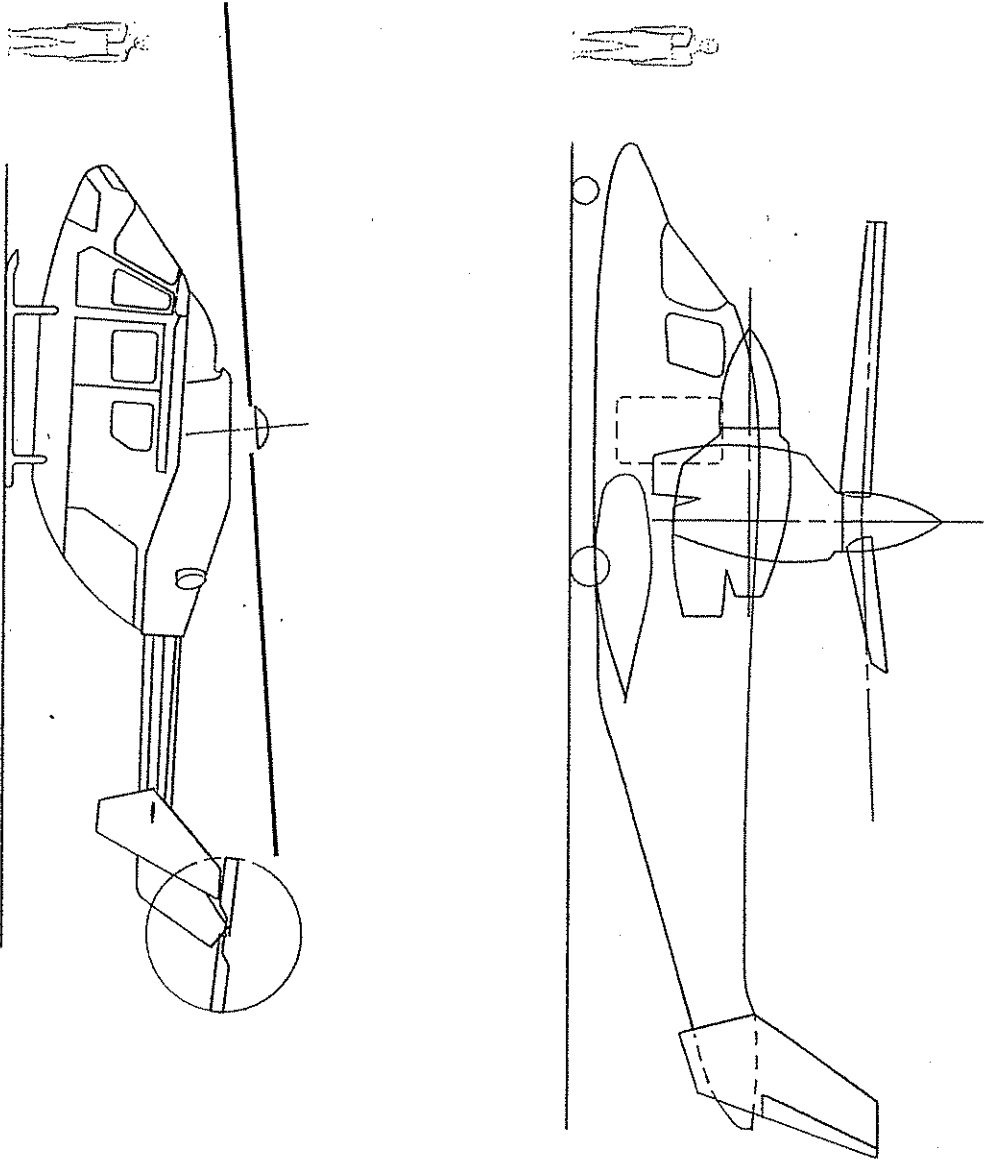

CONTRACT NO.		STANFORD UNIVERSITY	
PROJECT NO.		XV-15 TILTROTOR & BK117	
DRAWING NO.		SCALE 1/4"=1'	
DATE		SHEET NO.	
BY		DATE	
CHECKED		DATE	
APPROVED		DATE	
DESIGNED		DATE	
DRAWN		DATE	
SCALE		SHEET NO.	
C		DATE	

ADVANCED AEROMEDICAL TRANSPORT: SYNERGISTIC DESIGN FOR OPTIMUM MEDICAL & AERONAUTICAL PERFORMANCE

Eric E. Sabelman
Ahimsa P. Sumchai

Transportation of acute medical patients by air is an increasingly common practice, due to such factors as prolonged ground transit times, recent improvements in trauma victim survival if given prompt treatment, and a trend toward concentration of medical specialties in a few centers. Until now, there has been no aircraft of domestic manufacture designed especially to meet the requirements of patient transport. Short-range first-response aircraft are typically helicopters, which have limited internal space and lift capacity, high noise and vibration, and high maintenance and operating costs. Fixed wing aircraft for longer range aeromedical transport can land only at airports, have poor access for loading patient litters, and are incapable of adaptation for search-and-rescue missions.

The time is ripe for beginning a new effort to design and ultimately build an advanced aeromedical transport (AAT) aircraft using current technology for materials, propulsion and flight instrumentation. This effort cannot be solely the province of the traditional aircraft designer, however; the needs and new capabilities of the medical community are the driving factors underlying this proposal. Bringing the requirements of the "passengers" into the earliest stage of designing a new vehicle is uncommon, and the ability of the designer to incorporate their input and provide them meaningful feedback will be put to the test.

Improving the human factors aspects of the process of designing a mission-specific vehicle is a primary goal of the present proposal. Most often, a vehicle originally intended for general purpose use is adapted *post facto* to meet specialized needs. The present project provides an opportunity to retain some generalized aspects while building-in specialized components at the earliest stages of the design process. Two problems must be solved in order for this innovative design process to succeed:

Mission-specific needs must be translated into specifications guiding and constraining the design-in-process. Rather than a defined set of dimensional and material specifications, the needs of the user are expressed in the form of desired function: "I want to see out" or "We need to have IV solutions above the patient litter." These requirements must be converted into engineering terms, and if they impact upon functions of the vehicle with which the user is not concerned, the conflict must be reconciled with minimum disturbance to both basic function and mission requirements.

End users must be given a realistic picture of how the vehicle will look and behave under conditions of actual use, in the absence of a physical object. The user is accustomed to "putting his hands on" the vehicle, practicing his interaction with it, and requesting physical changes if it does not entirely meet his needs. If the vehicle exists only as a design--in traditional terms "on the drawing board"--how may it be presented so that he/she understands what its capabilities and limitations will be when it finally becomes physical reality? Experience has shown that blueprints, even when computerized and displayed on a screen, do not convey sufficient sense of reality. Rather, the design should be presented as a scenario or theatrical script: "Here you enter. . . now you sit here. . . reach over here for this piece of equipment. . . the vehicle starts and moves in that direction. . ."

ADVANCED AEROMEDICAL TRANSPORT

Goals

The principal motivation for this study is to achieve the best possible aircraft for the aeromedical transport mission, taking into consideration the needs of the patient, medical crew, pilot and operating agency, given current and anticipated technology. While the outcome of the study may well be a recommendation to develop a specific aircraft using Tiltrotor or other unconventional concepts, defining the characteristics of an advanced aeromedical transport would also:

1. Find contemporary applicability to conventional rotorcraft and fixed-wing aeromedical transports by resulting in new and/or modified technology.
2. Make possible a means of centralizing the airworthiness approval for the installation of medical equipment in all aviation transports.
3. Define intermediate, long and short range missions to small landing areas (*ie*: vertiports, offshore oil rigs, boats & island chains, accident scenes). A fundamental requirement is the capacity to transport 6-10 people plus cumbersome medical and extrication equipment.

The Advanced Aeromedical Transport must satisfy constraints derived from five principle areas of definition:

- A. The aeromedical market
- B. Characteristics of the carrier
- C. Identification and incorporation of advanced instruments and avionics
- D. Conceptualization and design of an advanced medical retrofit
- E. Ensuring FAA, NASA and NTSB approval of proposed designs

The Aeromedical Market

An advanced aeromedical transport must address the following missions defined by the functions of existing aeromedical transport programs:

1. air search and rescue - with first responder capability
2. organ donor and transport of replantation victims--team transport/harvesting/ organ preservation capabilities
3. accident scene response
4. neonate transports with specialized equipment needs
5. cardiac/intensive care unit patient transports with specialized equipment needs

Currently 200 aeromedical transport programs operate within the United States. In Germany and Switzerland, aeromedical transport offers expanded search and rescue capabilities. Air ambulances and flight crew function in the first responder capacity.

The journal *Hospital Aviation* annually surveys existing aeromedical transport programs - principally those which are hospital based. Results of the 1986 survey are reproduced in table form. Summary of this data yields the following important facts:

1. Average mission distance for rotorcraft aeromedical transports is 126 miles round trip
2. Average mission distance for fixed wing transports is 492 miles round trip.

Of the 78% of programs responding to the 1986 survey, 43% report fixed wing activity of more than 50 flights per year. The medical mix of patients is also presented, the predominate rotorcraft transport being for victims of trauma, cardiac and other medical emergencies. Therefore, it can be concluded that an advanced aeromedical transport can be developed to address a national need if it

ADVANCED AEROMEDICAL TRANSPORT

is most adaptable to intermediate and long range transports, and can meet the needs of the traumatized and critical cardiac or intensive care unit patient. The cost of an "AAT" must be competitive with land transport for short range missions (current average national transport charge for a 100 mile mission is \$722); higher cost of air transport may be justified by faster response, direct routing as opposed to street and highway travel, and service to specialized treatment centers.

The Aeromedical Carrier

Aeromedical missions can be classified as primary or secondary responses. In a primary response, the mission involves transport to the scene of an accident or injury. The mission is one of rapid response and a goal of take-off in 2 to 6 minutes with minimum flight time. A secondary response system receives requests from institutions that do not offer tertiary care services in all areas. Secondary response missions have inherently longer response times. A long distance response may be 150 to 500 miles. Very long transports may be greater than 500 miles. As a general rule the goal of carrier selection is to utilize an aircraft that restricts the time of patient transit to within 2 hours (J.I. Gilman, "Carrier and vendor selection", in *Critical Care Transport*, A. Hackel, ed., (International Anesthesiology Clinics, summer, 1987) 25(2):117-137).

Aeromedical aircraft are usually adapted from commercial airframes. Currently, there are no "ideal" air ambulances - all have been modified from general-purpose aircraft. Due to restricted size of the medical compartment, noise, vibration and lighting, a limited amount of work can be performed on the patient while in transit. Since helicopters do not have to follow a fixed route, they can approach a wide variety of locales. The average passenger compartment of a medical helicopter is approximately 4 to 5 feet (1.2 to 1.5m) wide, 4 1/2 feet (1.35m) high, and 5 to 7 feet (1.5 to 2.1m) in length with a volume of between 60(1.8m³) and 170 cubic feet (5.1m³). The size restrictions of the medical compartment dictate either rapid delivery to a care center or maximum stabilization prior to transport - particularly during interhospital transports (Gilman, *op cit.*).

Rotorcraft cannot fly safely in dense fog, at low altitudes, over varying or unfamiliar terrain, in icing conditions or in high winds or severe turbulence. With few exceptions, there may not be direct access for helicopters in residential or high rise areas that do not have provisions for helicopter landing.

The use of fixed wing aircraft may be essential to institutions which serve a wide region as a referral for specific medical needs such as organ transplant, limb reimplantation, burn care, high risk obstetrical and neonatal care. Although the fastest means of transport, fixed wing vehicles must use acceptable air fields which require secondary transport at both ends of the trip. A principle advantage to fixed wing transports rests in instrument flight regulations capability, which may allow transfer between airports in marginal weather conditions.

Fixed wing aircraft used for aeromedical transport should have twin engines with heating and air conditioning. Pressurization is required where flight altitudes exceed 6,000 to 7,000 feet. Size, speed, pressurization, noise, vibration and cost efficiency means that fixed wing aircraft used for aeromedical transport usually have turboprop rather than piston engines. Transports exceeding 400 miles are usually performed using a fast turboprop or pure jet. The common twin engine aircraft used for aeromedical transport include Beechcraft King Air, Commander variations, Piper, Cessna and Mitsubishi MU 2. The jets include Cessna and Lear. Usually 200 to 300 cubic feet of space is available in the medical compartment that is approximately 4 to 5 feet (1.2 to 1.5m) in maximum height, 4 to 5 feet (1.2 to 1.5m) in width and from 12 to 19 feet (4 to 5.7m) in length. Height and width dimensions are comparable to rotorcraft, while the length is comparable to ground ambulances (Figures 1, 2).

The characteristics of an "AAT" must face the realities of existing national trends. Few to no new

ADVANCED AEROMEDICAL TRANSPORT

airports are expected to service large urban areas and present major hub airports are nearing maximum air traffic capacity. NASA's Planning Group for Public Service Helicopter Technology Transfer (Nov. 22, 1983) determined that the properly designed and equipped EMS helicopter system can:

1. Reduce accident response time by 30-80%
2. Reduce mortalities by 50% in both trauma and high risk neonates
3. Transport patients to treatment consistent with their needs
4. Provide EMS service to areas where none is currently available
5. Increase the utilization of critical care facilities.

Such goals should be viewed as the **minimum** capabilities of an advanced aeromedical transport.

Conventional rotorcraft offer unique capabilities that cannot be duplicated by conventional airplanes. These capabilities allow the helicopter to perform certain tasks better or more competively than fixed wing aircraft. The principal unique capabilities of specific value to the public service market include:

1. Vertical takeoff and landing enabling landing on small surfaces
2. Slow to zero velocity to land on unprepared surfaces
3. Hover and Hover taxi to hoist and observe as in rescue and med-evac
4. Slow flight and small turning radius enabling safe slow flight in poor visibility and flight in specific airport approach patterns
5. Steep approaches and departures to land in inaccessible areas
6. Cargo hoist for rescue capabilities
7. Less sensitivity to wind than airplanes allows smoother flight in turbulent air
8. Use of skids, wheels or floats to land on unprepared surfaces and water

Rotorcraft Air Transportation Benefits and Opportunités, prepared by Helicopter Association International for NASA-Ames research center (Report #NASA CR-166266) defines the primary technological thrusts of rotorcraft development to be:

1. The use of advanced composite materials
2. The development of advanced cockpit designs with simplified controls and computerized flight aids
3. Advanced blade tip geometry and higher power margins to reduce noise footprints of future rotorcraft

This report also identifies principal EMS helicopter observations/needs of users, noting that key problems to be addressed are:

1. Unreliability of current helicopters
2. Interior noise prevents use of standard diagnostic/monitoring equipment
3. Vibration levels of current helicopters possibly harmful to some patients, particularly spinal and intestinal injury, but hard data are lacking.
4. External noise a problem for selecting hospital heliport sites
5. Foreign manufacturers more aggressively address EMS markets
6. Communications should improve among U.S. company divisions
7. Medical equipment must be approved by FDA
8. Many foreign EMS markets are more attractive than U.S.
9. 2-litter specifications
10. Access to patients head and airway is critical in helicopter and litter placement must facilitate both rapid loading and head/airway access
11. More definitive studies needed on head/neurotrauma and other (non-trauma) emergencies.

ADVANCED AEROMEDICAL TRANSPORT

The Executive Summary of the *Emergency Medical Service Rotorcraft Technology Workshop* (Washington, D.C. Oct 14-15, 1981) concludes that key technological needs for the EMS helicopter of the future are:

- Ride quality of a fixed wing aircraft, *ie*: reduced internal and external noise, reduced vibration
- No tail rotor
- Small rotor diameter
- Improved visibility from cockpit
- Crashworthy vehicle
- IFR capability
- More affordable
- High reliability
- Fuel efficient
- Specialized cabins for advanced medical/diagnostic and communications equipment.

A civil aeromedical transport using the technology proven by the XV-15 Tiltrotor research aircraft would have several intrinsic advantages over helicopters presently employed in this service. These advantages originate in the combination of vertical flight with the characteristics of fixed wing aircraft during forward flight. The fabrication and control technology of the existing prototype XV-15s is in need of updating. The 8-10 passenger CTR-800 is on the drawing board and can be developed into an efficient AAT if early design modifications can be incorporated. These include door size and location, cabin pressurization, wire strike protection and emergency float gear. A medically configured tiltrotor design could incorporate all user tasks including first response capabilities. The design effort will concentrate on adaptation of the fuselage, including internal dimensions, crew placement, ingress and egress for both patient and crew and location of medically significant facilities. As few changes as possible will be made in the design of the airframe, cockpit, propulsion and aerodynamic components, so as to minimize the need to repeat airworthiness simulation and flight tests and to amortize the development and production costs over the largest possible number of aircraft. Also, the XV-15/CTR-800 appears to be sized to have the minimum lifting capacity and the maximum rotor area (or landing footprint) desirable for foreseeable aeromedical missions.

Advanced Instruments and Avionics

Recent studies of EMS helicopter accidents suggest that as many as 75% of accidents are due to pilot error. However, errors seem to be due to fatigue and to continuation of missions after weather or landing conditions become untenable, rather than to easily remediable factors such as undertraining or unfamiliarity with the aircraft. Improving the medical environment within the aircraft or changing to a different VTOL propulsion modality will not in itself result in improved safety. Hence, the next generation AAT will need to be equipped with means for improving pilot performance. In particular, the high level of concentration needed to fly current helicopters should be reduced, by providing electromechanical control assist, navigational aids and reduced cockpit noise and vibration. Isolation of the cockpit from the cabin containing the medical crew and patient is advantageous in reducing distraction to the pilot, as long as communication between flight and medical crew is still possible. The flight crew should not be involved in medically-related radio communications, except when directly impacting upon the pilot's role.

Although few changes will be made in the design of the airframe, cockpit, propulsion and aerodynamic components, the study will investigate and make recommendations regarding technological advancements in avionics and instrumentation which will facilitate the safe conduct of aeromedical transport. Advanced cockpit designs which serve to improve pilot visibility, simplify controls and identify automated flight aids including CRT's (cathode ray tubes) and voice interactive systems to aid operation in inclement weather. The role of the automatic pilot will be explored in conventional rotorcraft and tiltrotor aeromedical adaptation,

ADVANCED AEROMEDICAL TRANSPORT

with a goal towards shift of the pilot to being commander of the vehicle rather than manipulator of controls. Focus on greater utilization of the computer to detect incipient maintenance failures in flight, make navigational calculations for the pilot and provide an instantly retrievable library of information.

Advancements in Medical Retrofit and Physiologic Monitoring

The report of NASA's Public Service Helicopter Technology Transfer planning group defines the need for the following advanced medical equipment.

1. Medical monitoring in-flight telemetry
2. Accurate monitoring of blood pressure, respiration, and pulse rate in a helicopter environment (due to interior noise, cannot listen to heart sounds.) Pressure monitoring: arteria, cardia, and chamber.
3. Accurate, rapid read-out of blood gasses ($p\text{ACO}_2$, $p\text{AO}_2$) and blood pH
4. Interactive diagnostic information CRT Display to aid medical crew in helicopter
5. Miniaturization of equipment is critical (i.e.: EKG, respirator, incubator, balloon pump, transcutaneous pacer)
6. Human factors analysis of medical equipment location within medical crew compartment
7. Environmental control system for pressurization, smog and toxic environments
8. Light weight/High O_2 supply source, such as: composite high pressure O_2 vessel, LOX container, engine bleed air for O_2 source, light-weight flow regulators
9. Small litter weight - 40 lbs maximum for 2-man crew

Much of the technology needed to utilize advanced medical equipment has been developed but has yet to be applied to the medical retrofit of existing rotorcraft and fixed-wing aeromedical transports. Its incorporation into the medical compartment of the AAT design would be of benefit in current applications by stimulating new and/or modified technology.

FAA, NASA and NTSB approval

In addition, the AAT and its operations must conform to the recommended minimum quality standards for hospital based emergency air medical services and the newly developed guidelines for EMS Helicopter operations set by the National Transportation & Safety Board. Both of these documents are enclosed. Such approval would meet the principle goals of an investigation to define the characteristics of an advanced aeromedical transport:

1. To investigate and recommend an AAT complete unit to set a world-wide standard of excellence
2. To develop a human factors-optimized AAT design that would make it possible to centralize the airworthiness approval for installation of medical equipment in all aviation transports.

ADVANCED AEROMEDICAL TRANSPORT

Methods

Our approach is based on the synergistic combination of the skills and resources of two communities: engineering design and medical transport. This combination of viewpoints has led to the awareness that (1) the medical transport community feels that current vehicles have deficiencies which will become increasingly apparent as more demands are made upon them, and (2) there exist prototype and conceptual aircraft which potentially could better serve the user community if sufficient attention were paid to user needs early in the design process, and if the design process is begun expeditiously so that less capable vehicles are not adopted by default.

Given that development of a new AAT vehicle will necessarily be a prolonged iterative process, involving the contribution of many agencies and individuals, what can be done at the present time to facilitate the flow of information between the participants in the process? Our proposed contribution to the evolution of the AAT is to:

1. Identify the requirements of the user community unmet by current vehicles,
2. Determine characteristics of candidate vehicles that meet these needs,
3. Suggest modifications to vehicle designs and equipment to enhance the match between capabilities and needs,
4. Prepare computer and physical simulations demonstrating candidate vehicles' capabilities,
5. Present these candidates to users and manufacturers and integrate the feedback from these sources into the design process, and
6. Examine the above stages of the design process and suggest improvements for the next iteration.

Identification of User Needs

There are three components of the user community whose needs must be taken into account in design, manufacture and operation of the AAT, exemplified by: (1) the medical crew, whose primary concern is the welfare of the patient, (2) the pilot(s), whose concern is the rapid and safe flight of the aircraft, and (3) the operating agency, which must consider such factors as vehicle availability and cost in addition to crew and pilot concerns.

This phase of the project will employ typical mission scenarios for: (1) accident scene call, (2) inter-hospital transport, (3) land search-and-rescue, (4) sea search-and-rescue, and (5) other related functions. These scenarios will incorporate data on: (1) medical crew size and make-up, (2) length of flight (in-city, inter-city, rural), (3) patient capacity, (4) patient-specific needs (e.g.: attitude and acceleration limits, temperature and atmosphere control, time criticality), and (5) environmental factors, such as weather, landing site terrain and presence of other air traffic.

Data will be acquired by (1) compilation of existing surveys, (2) conducting a specific survey, and (3) extrapolation of trends. Even the preliminary compilation to date has indirectly revealed unmet needs; for example, average flight length is 246 miles for fixed-wing medical transports and 63 miles for helicopters. These averages imply that flights between these distances are made less frequently, for reasons that should be elucidated by the specific survey to be conducted as part of this phase. It could be that lack of aircraft that are well-adapted to missions of this length is the determining factor, or there may be in fact no need for flights of intermediate length due to geographic distribution of hospitals.

ADVANCED AEROMEDICAL TRANSPORT

Candidate Vehicle Identification

The following survey of the potential of the XV-15 Tiltrotor aircraft may serve as an example of the search for a candidate AAT:

1. Safety and reliability:
 - Glide capability
 - Cross-coupled wingtip-mounted twin engines
 - No tail rotor; main rotors pose no danger in landing configuration
 - Reduced pilot workload in forward flight compared to helicopter
 - Reduced vibration, thus less component fatigue compared to helicopter
 - Compatible with fixed wing traffic control
2. VTOL capability
 - Footprint near that of existing helicopters
 - Can operate from rooftop helipads
 - Independent rotor/fuselage attitude
 - Can loiter at scene at long range
3. Patient care and comfort
 - Fuselage orientable relative to acceleration
 - Reduced noise and vibration compared to helicopter
 - Potential rear or side loading
 - Greater fuselage length and volume than helicopter
4. Design features requiring further attention
 - Effect of rotor downwash on patient loading
 - Possible need for engine exhaust heat suppression
 - Improvements to power and tilt cross-coupling
 - Present configuration for two pilots only

Modifications to Match Capabilities and Needs

This phase will use information acquired during the previous two phases to ascertain whether changes are needed to improve the relative standing of a candidate vehicle. It will include:

1. Re-examination of overall dimensions
2. Addition of flight control aids (via fly-by-wire or optical coupling)
3. Addition of IFR instruments
4. Change from fixed (retrofit) to modular (multi-mission) equipment

Demonstration of Candidate Vehicles

Each candidate vehicle design will be examined first in the form of a computer simulation, which would permit semi-animated enactment of a mission scenario (e.g.: patient loading and access in flight). One or more final candidates would be mocked-up at full scale so that actual equipment could be evaluated. These simulations would incorporate such parameters as:

1. Cabin access door and window location
2. Cabin, fuselage and overall dimensions

ADVANCED AEROMEDICAL TRANSPORT

3. Cabin interior equipment layout (e.g.: litter and seat locations, medical apparatus and supplies, lighting)
4. Size and location of utilities (e.g.: electrical power, oxygen, suction)
5. Cockpit layout, including pilot complement, isolation from and communication with the cabin
6. Control panel and instrumentation complement
7. External facilities, such as hoists, cable strike deflectors and water landing equipment

Presentation to and Feedback from Users and Manufacturers

The deliverables for this project consist of a series of reports and presentations summarizing the results of each phase. To the extent desired by the funding agency, each report in the series will refine the results obtained previously. The earliest stage of the series will provide directions for future analyses of user needs and vehicle capabilities, whether conducted by us or by others. If the series continues to its logical extreme, each of the foregoing phases will be iterated several times, with responses to earlier stages forming part of the initial conditions for the next iteration. The ultimate product will be the specification of the design of an AAT vehicle optimized for both current and extrapolated future needs, suitable for flight prototype fabrication contract negotiation.

The specific reports to be prepared and presented to the sponsoring agency, potential users, operators and manufacturers are:

1. Need survey and mission analysis report,
2. Description and justification of candidate vehicle(s), including airframe and aerodynamic drawings and specifications (if not available from other sources) and cabin layout drawings and graphic simulations,
3. Mission scenarios, including dynamic human factors analysis (i.e.: medical and flight crew activities at successive times during a typical mission),
4. Full-scale cabin and/or cockpit mock-up,
5. Design process analysis report, as described below.

Design Process Examination

The end result of this phase is a detailed description of the design process as it has proceeded through the foregoing phases, identifying weak points and suggesting means for overcoming communication impediments. Although no final answers are likely to be forthcoming, this review will address the following questions:

1. How well does user/designer/manufacture communication work?
2. How can user needs be translated into design specifications?
3. How does the designer operate?
4. How can end users be given opportunity to judge a design-in-process?

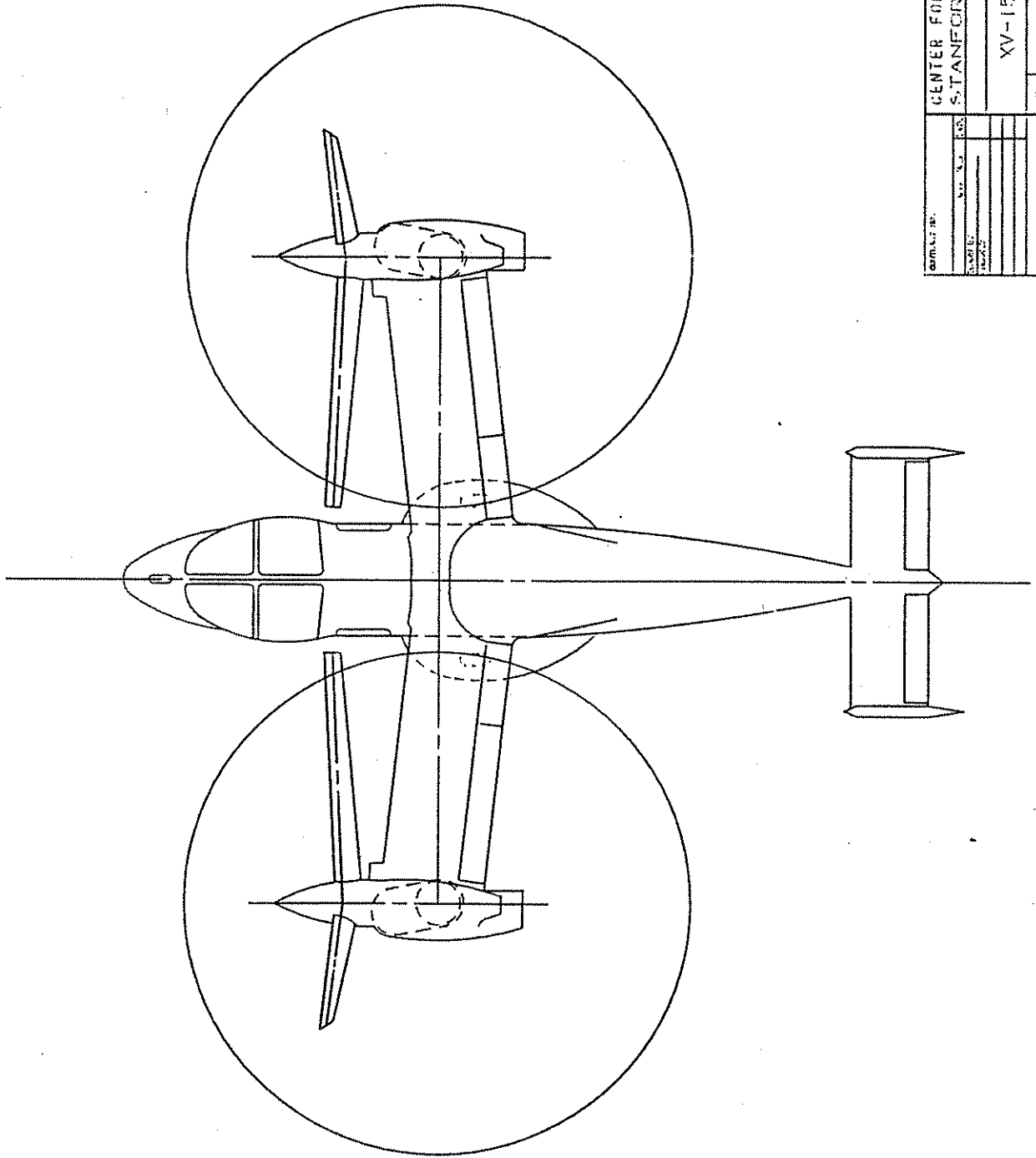

FORM NO.	DATE	CENTER FOR DESIGN RESEARCH STANFORD UNIVERSITY	
SCALE		XV-15 TILTROTOR	
REV.		C	DATE
		1/25/71	1971

Special report Rescues gone wrong

The air ambulance industry

About 750 helicopters operate as air ambulances in the USA, according to the Association of Air Medical Services. That's up about 50% from the late 1990s. Those helicopters carry 350,000 to 400,000 patients a year.

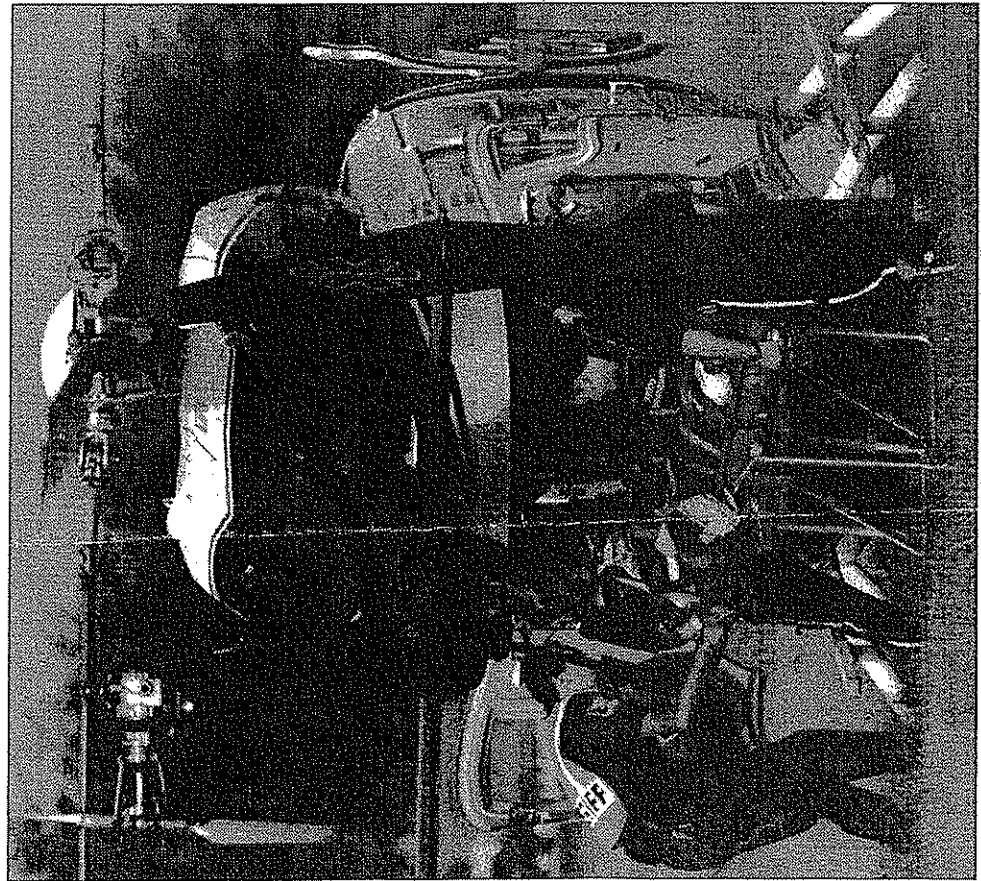

Evacuation: Person hurt by falling tree is loaded onto helicopter near Jacksonville last August. AP

Born out of war
Air ambulance companies got their start in the USA after doctors in the Vietnam War saw how many lives were saved by airlifting wounded troops to well-equipped hospitals. The first commercial service began in Denver in 1972. The number of programs more than tripled from 1981 to 1986.

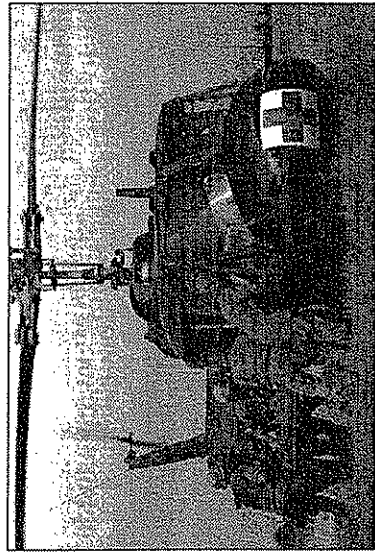

AP
Vietnam: Wounded soldier moved from battlefield in 1967.

Safety consequences

A series of accidents in the 1980s led the National Transportation Safety Board to study air ambulances. It found that most accidents were preventable, and it recommended tighter standards, better training and improved government oversight. The number of accidents dropped and remained low until the mid-1990s.

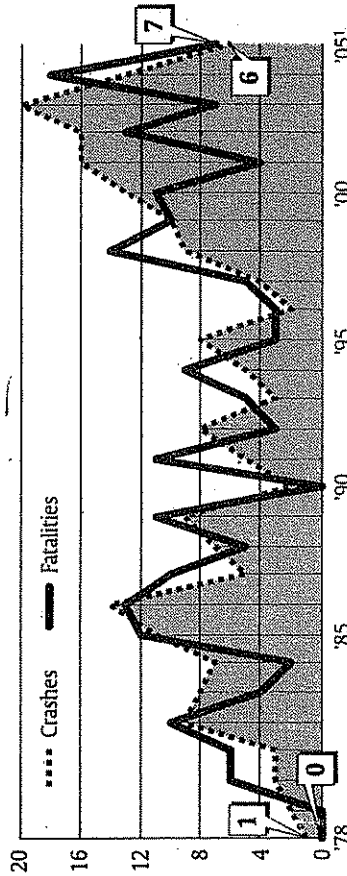

1 - through July 15

Sources: National Transportation Safety Board, Flight Safety Foundation, Air Medical Physician Association, USA TODAY research

Making the call
Patients with multiple or internal injuries are most likely to be flown to a hospital. Medical workers on the scene decide who needs a helicopter.



Called in: Helicopter collision of truck near Yoder, Kan., AP

A changing sy
Changes in the h meant more wor rural hospitals h money or have d limited the kind a result, more pa-tients have to be taken long dis-tances to receive ex-pert care.

The price tag
An air ambulance on average, thou- tion. Private insu- of flights. Medica Medicare payme- licopter services

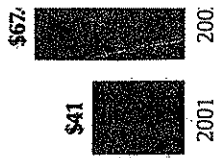



SCau:
07/16/2009 02:35 PM

To Board.of.Supervisors@sfgov.org
cc
bcc

Subject Library Citizens Advisory Committee Annual Report

BOS Clerk's Office:

Please post the BOS Library Citizens Advisory Committee's FY 08-09 Annual Report in Petitions & Communications.

Thank you,

Sue Cauthen, Chair

Sue Cauthen

San Francisco, California

Can love help you live longer? [Find out now.](#)

23

**Document is available
at the Clerk's Office
Room 244, City Hall**

ANNUAL REPORT

LIBRARY CITIZENS ADVISORY COMMITTEE

June 30, 2009

Sue Cauthen, Chair
(415) 391-0737
SCau1321@aol.com

NOTE: The colored pages in this document are printed on acid--free 30% recycled paper.

**Board of
Supervisors/BOS/SFGOV**

07/14/2009 12:10 PM

To BOS Constituent Mail Distribution,

cc

bcc

Subject Fw: Access TV

SOTF/SOTF/SFGOV

07/13/2009 10:13 AM

To Board of Supervisors/BOS/SFGOV@SFGOV

cc

Subject Fw: Access TV

----- Forwarded by SOTF/SOTF/SFGOV on 07/13/2009 10:14 AM -----



"amanda \"mandy\" egron"

>

07/13/2009 09:46 AM

To sotf@sfgov.org

cc "amanda \"mandy\" egron" <amanda@mandysplace.org>

Subject Access TV

Dear Board of Supervisors,

I am writing today to express my concerns about the takeover of Access TV by the group known as BAVC. While I am a supporter of BAVC in general, I find that their proposal is sorely lacking.

BAVC is taking the "PUBLIC" out of Public Access TV and putting their own brand of editorial censorship on the broadcast stations associated with Public Access TV. This is censorship at it's worst. The shows produced by the citizens of SF may not be the cup of tea BAVC would like them to be but they are honest and true to the producers vision and go a long way toward representing and expressing the views of the under-served populations of San Francisco.

We do not need another KQED!!!!

We need a truly, diverse, public television channel that is self censoring not another curated mainstream channel.

The web is a wonderful medium but it is not a replacement for a public access broadcast channel.

As a producer, my aspirations for future shows on Access SF would go out the window with BAVC's proposal. Access to the broadcast production studio would no longer exist. Contrary to BAVC's proposal, not all shows can be produced in the flash studio and streamed on the web. I would also dare to say that the majority of producers do not have the resources, (i.e., money,

24

equipment, technical expertise) to produce a show of any kind without the resources provided by the old Access SF. (i.e.. a full television Production Studio, equipment checkout... cameras, lighting, microphones, etc., Dubbing, and Editing suites) at little or no cost to the producer.

Please reconsider your vote to allow BAVC to take over Access SF. Their proposal leaves much to be desired and needs to be rewritten in order to become all inclusive and support community building in San Francisco.

Stop the censorship of the people of San Francisco on broadcast TV before it spreads.

Sincerely,

Amanda Egron (a citizen of San Francisco and a producer, director at Public Access-SF)

Board of
Supervisors/BOS/SFGOV

07/17/2009 05:27 PM

To Lolita Espinosa/BOS/SFGOV, Rana Calonsag/BOS/SFGOV,
Alistair Gibson/BOS/SFGOV,

cc

bcc

Subject Fw: BOARD OF SUPERVISORS INQUIRY # 20090714-005

Complete a Board of Supervisors Customer Satisfaction form by clicking the link below.

http://www.sfgov.org/site/bdsupvrs_form.asp?id=18548

----- Forwarded by Board of Supervisors/BOS/SFGOV on 07/17/2009 05:29 PM -----



"Roberts, Kingsley"
<Kingsley.Roberts@sfdpw.org>

07/17/2009 03:07 PM

To Board of Supervisors <Board.of.Supervisors@sfgov.org>

cc "McDaniels, Chris" <Chris.McDaniels@sfdpw.org>, "Lee,
Frank W" <Frank.W.Lee@sfdpw.org>, "Mirkarimi, Ross"
<Ross.Mirkarimi@sfgov.org>

Subject RE: BOARD OF SUPERVISORS INQUIRY # 20090714-005

Gentlemen,

We inspected and paved out potholes in the intersection of Fillmore and Golden Gate on May 15, 2009.

Kingsley Roberts
Assistant Superintendent
Department of Public Works, BSSR
2323 Cesar Chavez
San Francisco, CA 94124
Phone: 415-695-2087
Fax: 415-695-2097

-----Original Message-----

From: McDaniels, Chris
Sent: Friday, July 17, 2009 10:50 AM
To: Roberts, Kingsley
Subject: FW: BOARD OF SUPERVISORS INQUIRY # 20090714-005

Sent from my Windows Mobile(r) phone.

-----Original Message-----

From: Rodis, Nathan <Nathan.Rodis@sfdpw.org>
Sent: Friday, July 17, 2009 10:47 AM
To: McDaniels, Chris <Chris.McDaniels@sfdpw.org>
Cc: Nuru, Mohammed <Mohammed.Nuru@sfdpw.org>
Subject: FW: BOARD OF SUPERVISORS INQUIRY # 20090714-005

Chris,

25

Please respond directly to the Board of Supervisors and copy Supe. Mirkarimi. Please use the reference number in your reply title, and copy Frank W. Lee and myself because we are tracking these requests.

Thank you!

Nathan Rodis
Assistant to the Director's Office
Department of Public Works
1 Dr. Carlton B. Goodlett Place
City Hall, Room 348
San Francisco, CA 94102
Ph: (415) 554-6920 Fax: (415) 554-6944

-----Original Message-----

From: Board of Supervisors
Sent: Thursday, July 16, 2009 11:03 AM
To: Reiskin, Ed
Subject: BOARD OF SUPERVISORS INQUIRY

BOARD OF SUPERVISORS INQUIRY
For any questions, call the sponsoring supervisor

TO: Edward Reiskin
Public Works

FROM: Clerk of the Board
DATE: 7/16/2009
REFERENCE: 20090714-005
FILE NO.

Due Date: 8/15/2009

This is an inquiry from a member of the Board of Supervisors made at the Board meeting on 7/14/2009.

Supervisor Mirkarimi requests the following information:

Requesting the Department of Public Works to report on the status of repairing potholes at the following locations: On Fillmore & Golden Gate, in the middle of intersection

Please indicate the reference number shown above in your response, direct the original via email to Board.of.Supervisors@sfgov.org and send a copy to the Supervisor(s) noted above.

Your response to this inquiry is requested by 8/15/2009



MEMORANDUM

July 9, 2009

TO: MEMBERS, PORT COMMISSION
Hon. Rodney Fong, President
Hon. Stephanie Shakofsky, Vice President
Hon. Kimberly Brandon
Hon. Ann Lazarus
Hon. Michael Hardeman

FROM: Monique Moyer *M Moyer*
Executive Director

SUBJECT: Annual Contracting Activity Report – Fiscal Year 2008/09;
4th Quarter Period April 1, 2009 through June 30, 2009

RECEIVED
BOARD OF SUPERVISORS
SAN FRANCISCO
2009 JUL 16 PM 2:56
BY *[Signature]*

DIRECTOR'S RECOMMENDATION: Informational Item – No Action Required

INTRODUCTION

The purpose of this report is to provide regular reporting of the Port's contracting activities as legally required by the City and County of San Francisco through its Administrative Code or based upon policies and practices adopted by the San Francisco Port Commission. Background information on these requirements is provided at the end of this report as Exhibit 1.

This report includes a summary of: 1) 4th Quarter Period for Fiscal Year 2008-09 contracting activities and Local 21 staffing changes; 2) annual statistical data, 3) as-needed contracting three year data; and 4) projected upcoming contracting activities.

SUMMARY

Based upon Port historical procurement volume, the 2008/09 Fiscal Year has been a very busy year for contracting. Formally procured contracts awarded this fiscal year include the following:

- Brannan Street Wharf Project Engineering Design
- Youth Employment Program – Environmental Maintenance of Port Infrastructure
- Financial Advisory Services
- Pier 70 Brownsfield Environmental

This Print Covers Calendar Item No. 7E

[Handwritten signature]

- Elevator/Escalator Maintenance
- As-Needed Engineering Services
- Coastal Engineering Services for Mission Bay Bayfront Park Shoreline Protection

In addition to the above, the Port has embarked upon other projects of significance to the Port using the as-needed contracts. These projects include:

- Pier 43.5 Detailed Condition Survey and Conceptual Plan
- Pier 45 Drainage Improvements
- Access Control System Programming
- CCTV System Programming
- Pier 35 Fire Alarm Upgrades
- Pier 1 Server Emergency Power Lighting Upgrade
- Army Corp of Engineers and Regional Water Quality Control Board permitting support consulting services for the Brannan Street Wharf Project
- Maritime Cargo and Land Use Study
- Pier 50 Valley Substructure Repair Project
- Consulting Services to assist with SWL 351 Development Evaluation
- Pier 35 Superstructure Shed Structural Evaluation
- Piers 68 & 70 Utility Mapping/BAE Electrical Separation

Considering all of the above contracting activities, the Port achieved local business enterprise subcontracting participation of 26.89%; exceeding its goal of 20%.

I. 4th Quarter, FY 2008/09 Contracting/Local 21 Activities:

New As-Needed Engineering & Related Services Contracts Awarded - 4TH Quarter

Blanket Master Agreements for Engineering & Related Services	Amount Awarded	LBE Amount	LBE %
As-Needed Professional Services -	\$3,000,000	\$600,000	20%
TOTAL	\$1,500,000	\$300,000	20%
• Creegan & D'Angelo/FE Jordan JV	\$1,500,000	\$300,000	20%
• Winzler & Kelly/SDE Engineers			

The Port of San Francisco has met the 20% Disadvantaged/Local Business Enterprise (D/LBE) participation goal for as-needed contracts with the participation level at 69.07% for this quarter. Most of this D/LBE participation represented environmental professional services. One single Contract Service Order (CSO) was issued to URS/Avila Joint Venture for Brannan Street Wharf CEQA and Permitting Support. This CSO alone included 87% LBE participation out of a total of five (5) CSOs issued during this reporting period.

This decline in CSO (five CSO transactions) usage is due primarily to the fact that no new CSOs under the Port's as-needed contracts could be issued after April 10, 2009 pursuant to the San Francisco Administrative Code requirements. The first two quarters

of the fiscal year resulted in 11 CSO transactions and the average for the prior year was 17 per quarter. Additional details are provided in Exhibit 2 to this report.

Local 21 Staffing Activity for Fiscal Year 2008/09 4th Quarter, 4/1/09 – 6/30/09

Class/Title	Activities
1053 IS Business Analyst-Senior	(Vacancy due to release of PCS employee) - a new PCS appointment made eff. 6/24/09 from the Registry.
1652 Sr. Accountant	(Vacancy due to retirement) - Backfill of the position on hold pending budget review.
5382 Design Trainee III	(As needed position in Engineering Division) – temporary exempt appointment made eff. 6/15/09.
9395 Property Manager	(Vacancy due to retirement) – PCS appointment made eff. 6/1/09 from eligible list.

II. Annual Report Contracting Activity

The following tables summarize the Port's Annual Contracting Activity for FY 08/09.

Type of Contract	Amount Awarded	LBE Amount	LBE %
As-Needed Professional Services (Master Contracts – Total of 33 CSOs issued)	\$ 1,530,844	\$ 437,884	28.6%
General Services (Contracts Only)	\$ 99,600	\$ 99,600	100%
Professional Services	\$ 2,194,982	\$ 503,114	22.92%
Construction Services	\$ 185,000	\$ 37,850	20.46%
Totals	\$ 4,010,426	\$1,078,448	26.89%

Contracting Activities that were exempt from D/LBE participation for FY 08/09

TYPE OF LBE EXEMPT CONTRACT	Contract Amount	D/L/SBE Amount	D/L/SBE *
Administrative Code	\$ 81,284	0	0
Federal Contracts	\$1,422,702	\$453,790	31.8%
Sole Source Contracts	\$3,809,754**	\$ 4,725	.12%
HRC Waiver	\$ 800,000	0	0
Totals	\$6,113,740	\$458,515	7.5%

*SBE = federal small business enterprise participation requirements.

**Includes Board of Supervisor's authorization to award contract for shoreside power.

III. Three year summary of as-needed contracting activities:

Overall, the Port has been quite successful in meeting its goal for Disadvantaged/Local Business Enterprise (D/LBE) participation on its contracts. Six (6) or 50% of its as-needed contracts include Disadvantaged Business Enterprise (DBE) Joint Ventures. These joint venture contracts provide for participation of local disadvantaged

businesses as prime consultants for growing small businesses as well as subconsulting opportunities for those business seeking growth opportunities.

The Port's overall D/LBE subcontracting participation has exceeded the 20% goal with a participation rate of 23.68%. (See Exhibit 4: Three Year Summary Report) The participation of D/LBE firms on Environmental As-Needed Contracts as been particularly successful at a rate of 34.05%. In spite of the challenges in securing D/LBE firms to perform marine engineering type work, the Port has met the 20% goal for engineering related as-needed contracts at 20.55% for the three year contract period.

All consultants met the 20% goal except as follows:

<u>As-needed Consultant</u>	<u>LBE Participation</u>
• Tom Eliot Fisch/Winzler & Kelly Joint Venture	17.60%
• BDI/ECS Joint Venture (Suspended)*	1.6%
• MCC2 Joint Venture (Suspended)*	0.0%
• AGS/LEE Inc. (Not Activated)	0.0%
• Bay Area Economics	6.73%

*Suspended due to lack of available work

Port staff intends to work with those firms that continue under contract to improve their participation of local businesses.

\$200,000 As-Needed Contracting Authorization

During fourth (4th) quarter of FY 2008/09, the Port Commission was not asked to approve any projects in which the use of as-needed contract services exceeded the approved \$200,000 threshold.

To date there have been a total of three (3) Contract Service Orders that have exceeded the \$200,000 threshold for Port Commission approval. These projects are as follows:

1. Pier 70 Master Plan Project increase from \$200,000 to \$500,000; and
2. Pier 45 Drainage Improvement Project increase from \$200,000 to \$250,586.
3. Pier 52 Boat Launch Project at \$230,000.

IV. Projected Contracting Activities for the Upcoming Year:

Anticipated Construction Services Contracts to be Bid through Engineering

- Pier 80 Lighting (Est. \$1.4 million)
- 401 Terry Francois ADA Accessibility Upgrades (Est. \$500,000)
- Pier 45 Drainage Improvements (Est. \$2 million)
- Pier 9 Fire Protection (Est. \$60,000)
- SFPUC Efficient Lighting (Est. \$650,000)
- FW-Joint Security Operations Center (Est. \$6.9 million)

- Pier 50 Valley Substructure (Est. \$8 million)
- Pier 33 North Bulkhead Improvements (Est. \$840,000)
- Pier 94/96 Backlands-Ground Subsidence, Storm Drainage and Seawall Repair /Pier 94/96 Backlands Improvements (Est. \$8 million)
- Amador Street Swales (Est. \$425,000)
- Hyde Street Fuel Dock Substructure Repair (Est. \$1.5 million)

Construction-related Professional Services

Description of Work	Estimated Dollar Amount	Project
As-Needed Environmental & Related Services (RFP) (3 contracts at \$1,000,000 each)	\$3,000,000	Port-wide As-Needed Services
Design for repair of existing substructure of bridge leading to Sinbad Restaurant and Agriculture building east apron repair	\$50,000	Sinbad Bridge & Ag Bldg Walkway Repair
Roof Truss End Connections Engineering	\$12,000	Pier 35
Railroad Tunnel Modification	\$200,000	Pier 80
Pier 43.5 Engineering Design (RFP)	\$600,000	Bond funded Project
Design Development for automated bilge treatment system	\$15,000	SWL 303; Hyde Street
Dredging Inspections	\$50,000	Piers
CCTV Specification Development	\$50,000	Homeland Security
Blanket CSO for Project Scoping Services	\$75,000	Engineering Support
Investigate and design cost estimate for repairs	\$5,000	Pier 80 Shed A Walls
Design Services for Aprons 19, 26, 28 and 33 (separate projects)	\$400,000	Portwide Apron Repair
Seismic Upgrade and Fender Installation	\$50,000	Hyde Street Fuel Dock Substructure Repair
TOTAL ESTIMATED AMOUNT	\$4,507,000	

Real Estate and Related Consulting Services

(None Anticipated)

RECOMMENDATION

The attached report is submitted to meet the requirements stated in the report Background. In closing, staff requests the Port Commission's acceptance of this report.

Prepared by: Norma Nelson, Contract Administrator
 For: Tina Olson, Director of Finance & Administration

cc: ✓ Clerk, Board of Supervisors
 Local 21, IFPTE Representative Ging Louie
 Department of Public Works, Peg Divine
 Human Rights Commission, Selormey Dzikunu

Exhibits:

1. Report Background
2. FY 2008/09 4th Quarter As-Needed Contracting Activity Report
3. FY 2008/09 Annual Contracting Report including 4th quarter results
4. Three Year Summary of DBE Participation (As-Needed Contracts)

EXHIBIT 1

BACKGROUND

The purpose of this report is to comply with legal and policy mandates for the City and County of San Francisco and Port Commission. These legal and policy requirements are primarily based upon the following:

1. "As-Needed" contracting requirements as promulgated by Section 6.64 of the San Francisco Administrative Code, Port Commission Resolution 03-50 and a Letter of Agreement with Local 21 International Federation of Professional and Technical Employees Association (IFPTE). (Effective April 2005, a \$200,000 limit was imposed via City ordinance for use of as-needed contract services per each single public works project; not including general planning or non-construction related professional services such as real estate economics as-needed contracts.)
2. Local 21 Union for the IFPTE and the City and County of San Francisco Department of Public Works requested that the Port include the following additional information in the subject quarterly reports, as it applies to the use of as-needed professional service contracts:
 - Contracting activity for the current reporting period
 - Anticipated contracting activity for the upcoming quarter
 - Estimated staffing numbers and projects related to the as-needed contract services.
3. San Francisco Administrative Code Section 14(b) requires all departments and contract awarding authorities to report to the Mayor on their progress in the preceding fiscal year toward the achievement of the LBE goals and their steps to ensure non-discrimination against MBEs (Minority Business Enterprises), WBEs (Women Business Enterprises) and OBEs (Local businesses other than MBE or WBE).

The Port of San Francisco has been assigned by the San Francisco Human Rights Commission (HRC) an overall Disadvantaged Business Enterprise (DBE) or Local Business Enterprise (LBE) subcontracting participation goal of 20%. This means that 20% of all of contracted work procured by the Port of San Francisco must be awarded to Local Business Enterprises or the contractor must have demonstrated a good faith effort to do so.

In the award of leases, franchises, concessions, and other contracts not subject to the discount provisions of Administrative Code Section 14(b), contract awarding authorities such as the Port shall utilize the good faith efforts steps to maximize opportunities to for LBE participation, as deemed practicable to do so. At the minimum, contract awarding authorities should notify LBEs that are certified to perform the work contemplated in a contract and solicit their interest in the contract. These good faith effort steps are described in each solicitation for a

Port lease, franchise, concession and other contracts such as development agreements.

Definitions

1. *As-needed Professional Service Contracts* include professional service contracts procured on a request for qualifications basis to establish a pool of Master Agreements in which work is contracted under task orders or Contract Service Orders (CSOs), as needed to complete work required on an immediate basis that can not otherwise be performed by existing City and County of San Francisco staff. The Port has twelve as-needed contracts that have a total authorized contracting capacity of \$8,150,000.
2. *Professional Service Contracts* procured through a *formal* contracting process - contracts valued greater than \$29,000
3. *Professional Service Contracts* procured through an *informal* contracting process - contracts valued at less than \$29,000
4. *Construction Service Contracts*
- public works/construction contract means a contract for the erection, construction, renovation, alteration, improvement, demolition, excavation, installation, or repair of any public building, structure, infrastructure, bridge, road, street, park, dam, tunnel, utility or similar public facility that is performed by or for the City
4. *Information Technology Contracts*
- acquisition of computer hardware, software, peripherals and appropriate network, consulting, maintenance, training and support services, as well as any successor contracts
5. *General Services Contracts*
- an agreement for those services that are not professional services. Examples of "general services" include: janitorial, security guard, pest control, parking lot attendants and landscaping services

Other Contracting Activity

In addition to the above contracting activity, the Port has been engaged in number of leasing evaluations, renewals, and new leases. The Real Estate Division reports that all leases are conducted on a first come, first serve basis. There is no tracking by ethnicity, gender nor location of corporate headquarters for the tenants granted leases on Port property. However, the majority of the lease transactions are with local small businesses.

The Maritime Division contract for shoreside power equipment at Piers 27 and 29 has been approved by the Board of Supervisors as a sole source contract to a firm based in Seattle, Washington as selected by the primary end user, Princess Cruise Lines, Ltd. Princess Cruise Lines, Ltd is a co-applicant with the Port for the project funding. In addition, Port staff presented a report to the Port Commission at its May 13, 2008 meeting "regarding options for a Request for Proposals for Concrete and/or Asphalt Batching Plant at Seawall Lot 352 with a Bulk Maritime Terminal at Pier 94". At its May 27, 2008 meeting, the Port Commission authorized staff to issue a RFP (not yet issued) extending the opportunity for the lease and operation of a Concrete and/or Asphalt Batching Plant at Seawall Lot 352 with a Bulk Maritime Terminal at Pier 94.

Development contracting transactions are highly specialized and market driven by the private investment entities pursuing such projects on Port property. However, the Port still adheres to the Port's policy of encouraging participation of all local small businesses on its development projects without regards to race or gender. The Port has been engaged in two development projects that include the Piers 27-31 Mixed Use Recreation project and the Seawall Lot 337 project. It is anticipated that a Seawall Lot 351 RFP will be issued during the first quarter of FY 08/09. In all instances, the Port includes the following statement:

"V. OTHER PROJECT REQUIREMENTS

A. Equal Opportunity

The Port Commission encourages the participation of disadvantaged local business enterprises in this RFP opportunity. The selected Respondent will be encouraged to consult with the City's Human Rights Commission to determine appropriate methods for promoting participation by disadvantaged business enterprises in this opportunity. The City's list of certified Local Business Enterprises may be accessed through the following URL: (http://sfgov.org/site/uploadedfiles/sfhumanrights/directory/vlist_1.htm)."

Steps to Assure Non-Discrimination against MBEs, WBEs and OBEs

To assure that MBEs, WBEs and OBEs are not discriminated against in Port contracting opportunities, the Port has implemented the following standard procedures:

- Request information from the San Francisco Human Rights Commission as to the availability of MBEs, WBEs and OBEs certified as offering services required on Port projects. Such information includes availability statistics in percentages for MBEs, WBEs and OBEs. In addition, the Port has requested the MS Excel database of such certified firms to assure inclusion as project opportunities become available.
- Availability statistics in percentages are included in advertising for all formally procured contracts.
- Outreach through Minority, Women and Local media
- Direct mailing, faxing and e-mailing of procurement opportunity notices
- Identifying set-aside opportunities exclusively for Micro-LBE firms
- Working with Port staff to eliminate barriers to MBEs, WBEs and OBEs gaining access to Port contracting opportunities. Such barriers include qualifications based upon prior knowledge/experience on the project or past work with existing consultants.
- Hold prime consultants accountable for actions that impede the success of MBE, WBE and OBE firm's success on contracts such as the withholding of essential information required to perform subcontracted work by notifying the San Francisco Human Rights Commission to perform investigations, when deemed appropriate.

FY 2008/09 4th QUARTER AS-NEEDED CONTRACTING ACTIVITY REPORT

AS-NEEDED CONTRACTS	CSO#	CSO Description	CSO Amt	DBE Amt	DBE %
Architectural & Engineering					
Creegan + D'Angelo	-	No Activity			
Tom Eliot Fisch/Winzler & Kelly JV	-	No Activity			
Subtotal - A & E Services					
Environmental					
Treadwell & Rollo/Hydroconsult JV	TH-04	Site Assessment of Pier 90	\$ 29,167	\$ 24,808	85.06%
Subtotal Treadwell & Rollo	1		\$ 29,167	\$ 24,808	85.06%
Weiss Associates	WA-07	UST Soil /Groundwater Investigations	23,672	1,113	4.70%
	WA-07	UST Boring Repair (CSO Mod)	5,388	2,900	53.82%
Subtotal Weiss Associates	2		\$ 29,060	\$ 1,113	3.83%
URS Corp/Avila & Associates JV	URS-07	CEQA & Permitting Brannan Street	\$ 171,309	\$ 148,894	86.92%
Subtotal Weiss Associates	1		\$ 171,309	\$ 148,894	86.92%
Subtotal Environmental	4		\$ 229,536	\$ 174,815	76.16%
Construction Support Services					
BDI/ECS JV		No Activity			
Maritime Construction Coalition JV		No Activity			
Subtotal - CS Services	0				
TOTAL CONSTRUCTION-RELATED					
Real Estate Economics & Related					
Bay Area Economics		No Activity			
CBRE Consulting, Inc.	CBRE-03	Maritime Cargo & Industrial Land Use	\$ 23,573	\$ -	0.00%
Economic & Planning Systems, Inc.		Study Update			
Keyser Marston Associates		No Activity			
Subtotal - Real Estate Economics	1	No Activity			
TOTAL AS-NEEDED CSOs	5		\$ 253,109	\$ 174,815	69.07%

NEW AS-NEEDED CONTRACTS	\$1,500,000 each	FY 2008/09 4th Qtr		
		CSO Amt	LBE Amt	LBE %
Engineering & Related Services				
Creegan + D'Angelo/Fe Jordan JV		\$75,000.00	\$15,000.00	20.00%
Winzler & Kelly/SDE JV		\$0.00	\$0.00	0.00%
	Total As-Needed Eng Services	\$75,000.00	\$15,000.00	20.00%

Exhibit 2

	FY 08/09 1st Qtr		FY 08/09 2nd Qtr		FY 08/09 3rd Qtr		FY 08/09 4th Qtr		FY 08/09 TOTALS			
	CSO Amount	DBE Amount	DBE %	DBE Amount	DBE %	DBE Amount	DBE %	DBE Amount	DBE %	DBE %		
AS-NEEDED CONTRACTS												
Architectural & Engineering												
Greynan + D'Angelo	\$ 46,961	\$ 8,787	18.54%	\$ 19,458	\$ 11,346	58.31%	\$ 25,178	\$ 6,551	26.02%	\$ 91,597	\$ 26,604	29.04%
Tom Elvek Fitch/Wooder & Kelly JV	\$ 270,101	\$ 52,900	19.59%	\$ 235,214	\$ 13,711	5.81%	\$ 288,801	\$ 61,764	21.39%	\$ 794,116	\$ 140,923	17.75%
Total A&E Services	\$ 317,062	\$ 61,687	19.43%	\$ 454,672	\$ 25,057	5.51%	\$ 313,979	\$ 68,315	21.76%	\$ 885,713	\$ 173,527	19.59%
Environmental												
Treadwell & Robinson/Jones JV	\$ 121,653	\$ 22,893	18.82%	\$ 43,475	\$ 6,607	15.20%	\$ 29,167	\$ 24,808	85.05%	\$ 72,642	\$ 31,415	43.25%
Wress Associates	\$ 121,653	\$ 22,893	18.82%	\$ 51,707	\$ 35,062	67.85%	\$ 29,980	\$ 1,113	3.83%	\$ 202,400	\$ 59,098	29.19%
Total Environmental Services	\$ 243,306	\$ 45,786	18.82%	\$ 95,182	\$ 41,129	42.84%	\$ 59,147	\$ 14,921	25.17%	\$ 172,622	\$ 90,513	52.45%
TOTAL CONSTRUCTION-RELATED	\$ 438,696	\$ 84,900	19.26%	\$ 449,854	\$ 86,186	19.16%	\$ 313,979	\$ 83,236	26.52%	\$ 1,058,335	\$ 263,540	24.89%
Real Estate												
Bay Area Economics	\$ 75,245	\$ -	0.00%	\$ 99,962	\$ 24,960	24.97%	\$ -	\$ 23,573	0.00%	\$ 98,818	\$ -	0.00%
CBRE Consulting, Inc	\$ 75,245	\$ -	0.00%	\$ 99,962	\$ 24,960	24.97%	\$ -	\$ 23,573	0.00%	\$ 98,818	\$ -	0.00%
Economic & Planning Systems, Inc	\$ 75,245	\$ -	0.00%	\$ 99,962	\$ 24,960	24.97%	\$ -	\$ 23,573	0.00%	\$ 98,818	\$ -	0.00%
Koyser Marston Associates	\$ 75,245	\$ -	0.00%	\$ 99,962	\$ 24,960	24.97%	\$ -	\$ 23,573	0.00%	\$ 98,818	\$ -	0.00%
Total Real Estate	\$ 300,988	\$ -	0.00%	\$ 399,846	\$ 74,880	24.97%	\$ -	\$ 71,129	0.00%	\$ 396,454	\$ -	0.00%
Construction Support Svc												
BDUECS JV	\$ 513,841	\$ 84,900	16.44%	\$ 306,378	\$ 78,987	25.80%	\$ 313,979	\$ 83,215	26.52%	\$ 1,530,544	\$ 437,884	28.60%
Maritime Construction Coalition JV												
Total Construction Support	\$ 513,841	\$ 84,900	16.44%	\$ 306,378	\$ 78,987	25.80%	\$ 313,979	\$ 83,215	26.52%	\$ 1,530,544	\$ 437,884	28.60%
AS-NEEDED TOTAL	\$ 1,530,544	\$ 253,108.50	16.54%	\$ 1,177,756	\$ 410,659	34.50%	\$ 1,058,335	\$ 263,540	24.89%	\$ 4,378,884	\$ 1,173,527	26.81%

	FY 08/09 1st Qtr		FY 08/09 2nd Qtr		FY 08/09 3rd Qtr		FY 08/09 4th Qtr		FY 08/09 TOTALS			
	Contract Amt	LBE Amount	LBE %	Contract Amt	LBE Amount	LBE %	Contract Amt	LBE Amount	LBE %	LBE %		
NOT AS-NEEDED CONTRACTS												
Construction												
Accent Elevator	\$ 178,000	\$ 30,850	17.33%	\$ 178,000	\$ 30,850	17.33%	\$ 7,000	\$ 7,000	100.00%	\$ 7,000	\$ 7,000	100.00%
Security Electric, Inc	\$ 178,000	\$ 30,850	17.33%	\$ 178,000	\$ 30,850	17.33%	\$ 7,000	\$ 7,000	100.00%	\$ 178,000	\$ 30,850	17.33%
Subtotal of Construction Contracts	\$ 356,000	\$ 61,700	17.33%	\$ 356,000	\$ 61,700	17.33%	\$ 14,000	\$ 14,000	100.00%	\$ 356,000	\$ 61,700	17.33%
Professional Services												
Wardner & Kelly/Structus JV	\$ 1,539,956	\$ 379,209	24.62%	\$ 1,539,956	\$ 379,209	24.62%	\$ 300,000	\$ 60,000	20.00%	\$ 1,539,956	\$ 379,209	24.62%
Public Financial Management (PFM)	\$ 1,539,956	\$ 379,209	24.62%	\$ 1,539,956	\$ 379,209	24.62%	\$ 300,000	\$ 60,000	20.00%	\$ 1,539,956	\$ 379,209	24.62%
Coast & Harbor Engineering	\$ 1,539,956	\$ 379,209	24.62%	\$ 1,539,956	\$ 379,209	24.62%	\$ 300,000	\$ 60,000	20.00%	\$ 1,539,956	\$ 379,209	24.62%
Subtotal of Professional Services	\$ 1,539,956	\$ 379,209	24.62%	\$ 1,539,956	\$ 379,209	24.62%	\$ 300,000	\$ 60,000	20.00%	\$ 1,539,956	\$ 379,209	24.62%
General Services												
Mitch	\$ 99,600	\$ 99,600	100.00%	\$ 99,600	\$ 99,600	100.00%	\$ 99,600	\$ 99,600	100.00%	\$ 99,600	\$ 99,600	100.00%
Subtotal of General Services	\$ 99,600	\$ 99,600	100.00%	\$ 99,600	\$ 99,600	100.00%	\$ 99,600	\$ 99,600	100.00%	\$ 99,600	\$ 99,600	100.00%
TOTAL ALL OTHER CONTRACTS	\$ 2,475,556	\$ 470,509	19.01%	\$ 2,475,556	\$ 470,509	19.01%	\$ 703,600	\$ 166,600	23.83%	\$ 2,475,556	\$ 470,509	19.01%

	FY 08/09 1st Qtr		FY 08/09 2nd Qtr		FY 08/09 3rd Qtr		FY 08/09 4th Qtr		FY 08/09 TOTALS			
	Contract Amt	LBE Amount	LBE %	Contract Amt	LBE Amount	LBE %	Contract Amt	LBE Amount	LBE %	LBE %		
LBE PARTICIPATION EXEMPT												
Treadwell & Robinson (federal contract)	\$ 1,249,802	\$ 453,790	36.31%	\$ 1,249,802	\$ 453,790	36.31%	\$ 1,249,802	\$ 453,790	36.31%	\$ 1,249,802	\$ 453,790	36.31%
Cruiser/Factor (federal contract)	\$ 172,900	\$ -	0.00%	\$ 172,900	\$ -	0.00%	\$ 172,900	\$ -	0.00%	\$ 172,900	\$ -	0.00%
Sabash International (Per Admin Code)	\$ 37,484	\$ -	0.00%	\$ 37,484	\$ -	0.00%	\$ 37,484	\$ -	0.00%	\$ 37,484	\$ -	0.00%
Lands International (Per Admin Code)	\$ 14,000	\$ -	0.00%	\$ 14,000	\$ -	0.00%	\$ 14,000	\$ -	0.00%	\$ 14,000	\$ -	0.00%
Nelson/Newton (Admin Code)	\$ 10,000	\$ -	0.00%	\$ 10,000	\$ -	0.00%	\$ 10,000	\$ -	0.00%	\$ 10,000	\$ -	0.00%
URS Annapolis (Admin Code)	\$ 9,800	\$ -	0.00%	\$ 9,800	\$ -	0.00%	\$ 9,800	\$ -	0.00%	\$ 9,800	\$ -	0.00%
Carman Clark Consulting	\$ 800,000	\$ -	0.00%	\$ 800,000	\$ -	0.00%	\$ 800,000	\$ -	0.00%	\$ 800,000	\$ -	0.00%
San Francisco Conservation Corps	\$ 800,000	\$ -	0.00%	\$ 800,000	\$ -	0.00%	\$ 800,000	\$ -	0.00%	\$ 800,000	\$ -	0.00%
Total Other Exempt Contracts	\$ 2,083,986	\$ -	0.00%	\$ 2,083,986	\$ -	0.00%	\$ 2,083,986	\$ -	0.00%	\$ 2,083,986	\$ -	0.00%
Sole Source Contracts												
Cochran, Inc	\$ 31,501	\$ 4,725	15.00%	\$ 31,501	\$ 4,725	15.00%	\$ 31,501	\$ 4,725	15.00%	\$ 31,501	\$ 4,725	15.00%
Carry & Company	\$ 31,501	\$ 4,725	15.00%	\$ 31,501	\$ 4,725	15.00%	\$ 31,501	\$ 4,725	15.00%	\$ 31,501	\$ 4,725	15.00%
S F Gains	\$ 31,501	\$ 4,725	15.00%	\$ 31,501	\$ 4,725	15.00%	\$ 31,501	\$ 4,725	15.00%	\$ 31,501	\$ 4,725	15.00%
Aurit	\$ 45,000	\$ -	0.00%	\$ 45,000	\$ -	0.00%	\$ 45,000	\$ -	0.00%	\$ 45,000	\$ -	0.00%
Orndie	\$ 80,000	\$ -	0.00%	\$ 80,000	\$ -	0.00%	\$ 80,000	\$ -	0.00%	\$ 80,000	\$ -	0.00%
Invenys Systems, Canada, Inc	\$ 40,000	\$ -	0.00%	\$ 40,000	\$ -	0.00%	\$ 40,000	\$ -	0.00%	\$ 40,000	\$ -	0.00%
DLT, Autodesk Authorized Reseller	\$ 11,000	\$ -	0.00%	\$ 11,000	\$ -	0.00%	\$ 11,000	\$ -	0.00%	\$ 11,000	\$ -	0.00%
IBM	\$ 30,000	\$ -	0.00%	\$ 30,000	\$ -	0.00%	\$ 30,000	\$ -	0.00%	\$ 30,000	\$ -	0.00%
Total Sole Source Contracts	\$ 31,501	\$ 4,725	15.00%	\$ 31,501	\$ 4,725	15.00%	\$ 31,501	\$ 4,725	15.00%	\$ 31,501	\$ 4,725	15.00%
TOTAL EXEMPT CONTRACTS	\$ 2,115,487	\$ 4,725	0.22%	\$ 2,115,487	\$ 4,725	0.22%	\$ 2,115,487	\$ 4,725	0.22%	\$ 2,115,487	\$ 4,725	0.22%

	FY 08/09 1st Qtr		FY 08/09 2nd Qtr		FY 08/09 3rd Qtr		FY 08/09 4th Qtr		FY 08/09 TOTALS			
	Contract Amt	SBE Amt	SBE %	Contract Amt	SBE Amt	SBE %	Contract Amt	SBE Amt	SBE %	SBE %		
Number of Contracts Per Quarter												
Construction	0	1	2	1	4							
Professional Services	2	4	4	3	13							
General Services	0	5	0	0	5							
As-Needed CSOs	11	11	6	5	33							
FY 08/09 TOTALS (Exempt)	\$ 2,115,487	\$ 4,725	0.22%	\$ 2,115,487	\$ 4,725	0.22%	\$ 2,115,487	\$ 4,725	0.22%	\$ 2,115,487	\$ 4,725	0.22%
FY 08/09 TOTALS (Not-Exempt)	\$ 4,113,740	\$ 458,515	11.15%	\$ 4,113,740	\$ 458,515	11.15%	\$ 4,113,740	\$ 458,515	11.15%	\$ 4,113,740	\$ 458,515	11.15%

**FY 2008-09 Annual Contracting Report
Exhibit #3**

THREE-YEAR SUMMARY REPORT OF AS-NEEDED CONTRACTING ACTIVITY

For the Period: July 1, 2006 through June 30, 2009

Port of San Francisco

AS-NEEDED CONTRACTS	YEAR 1 (FY 06/07)			YEAR 2 (FY 07/08)			YEAR 3 (FY 08/09)			CUMMULATIVE		
	CSO AMT	DBE \$	DBE %	CSO AMT	DBE \$	DBE %	CSO AMT	DBE \$	DBE %	CSO AMT	DBE \$	DBE %
Architectural & Engineering												
Oreagan + D'Angelo	\$ 686,431	\$117,803	17.16%	\$ 543,093	\$ 164,666	30.32%	\$ 91,597	\$ 26,604	29.04%	\$ 1,321,121	\$ 309,073	23.39%
Tom Eliot Fisch-Winzler & Kelly JV	\$ 266,369	\$ 47,601	17.95%	\$ 211,590	\$ 29,115	13.76%	\$ 794,116	\$ 146,923	18.50%	\$ 1,272,075	\$ 223,839	17.60%
Subtotal - A&E Services	\$ 952,800	\$165,604	17.38%	\$ 754,683	\$ 193,781	25.68%	\$ 885,713	\$ 173,527	19.59%	\$ 2,593,196	\$ 532,912	20.55%
AWARD: \$1,500,000 EACH (\$3,000,000)												
Environmental												
Treas. Hill & Rallo-Hydroconsult JV	\$ 375,553	\$ 67,681	17.95%	\$ 71,547	\$ 31,569	44.12%	\$ 72,542	\$ 31,415	43.25%	\$ 520,742	\$ 130,564	25.07%
Triass Associates	\$ 146,002	\$ 48,958	33.53%	\$ 179,782	\$ 57,681	32.20%	\$ 202,400	\$ 59,088	29.19%	\$ 526,164	\$ 165,927	31.41%
JRS Corp-Arila & Associates JV	\$ 21,477	\$ -	0.00%	\$ 220,545	\$ 62,537	28.32%	\$ 171,309	\$ 148,694	86.92%	\$ 413,331	\$ 201,431	48.73%
Subtotal Environmental	\$ 544,032	\$116,539	21.42%	\$ 471,874	\$ 141,986	30.09%	\$ 446,351	\$ 239,397	53.63%	\$ 1,462,257	\$ 497,922	34.05%
AWARD: \$650,000 EACH (\$2,000,000)												
Construction Support Services												
SDI EGS JV	\$ 115,192	\$ -	0.00%	\$ 10,000	\$ 2,000	20.00%	\$ -	\$ -	0.00%	\$ 125,192	\$ 2,000	1.60%
Palmetto Construction Coalition JV	\$ 25,903	\$ -	0.00%	\$ 36,962	\$ -	0.00%	\$ -	\$ -	0.00%	\$ 62,865	\$ -	0.00%
EGS LEE Inc JV	\$ 142,095	\$ -	0.00%	\$ 46,962	\$ 2,000	4.35%	\$ -	\$ -	0.00%	\$ 189,057	\$ 2,000	1.05%
Subtotal - CS Services	\$ 1,638,927	\$282,143	17.22%	\$ 1,272,519	\$ 337,767	26.54%	\$ 1,332,064	\$ 412,924	31.00%	\$ 4,243,510	\$ 1,032,834	24.34%
AWARD: \$650,000 EACH (\$2,000,000)												
TOTAL CONSTRUCTION-RELATED												
Real Estate Economics & Related												
Bay Area Economics	\$ 155,050	\$ -	0.00%	\$ 96,515	\$ 16,920	17.53%	\$ -	\$ -	0.00%	\$ 251,575	\$ 16,920	6.73%
CBRE Consulting Inc	\$ -	\$ -	0.00%	\$ 232,025	\$ 96,542	42.47%	\$ 98,519	\$ -	0.00%	\$ 350,643	\$ 96,542	28.79%
Economic & Planning Systems Inc	\$ 159,834	\$ 19,089	9.55%	\$ 300,000	\$ 97,990	32.65%	\$ -	\$ -	0.00%	\$ 459,834	\$ 117,079	23.42%
Geysen-Houston Associates	\$ 23,423	\$ -	0.00%	\$ -	\$ -	0.00%	\$ 59,952	\$ 24,960	41.63%	\$ 123,385	\$ 24,960	20.23%
Subtotal - Real Estate Economics	\$ 378,317	\$ 19,089	5.05%	\$ 628,540	\$ 213,452	33.96%	\$ 198,780	\$ 24,960	12.56%	\$ 1,205,637	\$ 257,501	21.36%
AWARD: \$550,000 EACH (\$2,000,000)												
AS-NEEDED CSO TOTALS	\$ 2,017,244	\$301,232	14.93%	\$ 1,901,059	\$ 551,219	29.00%	\$ 1,530,844	\$ 437,884	28.60%	\$ 5,449,147	\$ 1,290,335	23.68%

Exhibit 4



**Bay-Delta Sport Fishing Enhancement Stamp Program
Proposal Solicitation Notice (PSN) is now available!**

RECEIVED
COUNTY SUPERVISORS
SACRAMENTO

2009 JUL 16 AM 11:02

The DFG Bay-Delta Sport Fishing Enhancement Stamp Program (BDSFES) is requesting proposals for projects that benefit sport fish populations, sport fishing opportunities, and anglers within the BDSFES geographic range. Golden Gate Bridge to the most downstream dam of the Sacramento and San Joaquin rivers and their tributaries. The PSN is on-line at www.dfg.ca.gov/fish/Administration/Permits/BayDeltaStamp/. An informational workshop will be held on **August 3, 2009 at 10:00** at the Yolo Wildlife Area Headquarters in Davis.

For 2009/2010 proposals, the BDSFES Advisory Committee will give additional points to projects within these focus areas.

Focus One: Projects focusing on bay and delta fisheries that may result in recommended management actions to better protect bay-delta fisheries and their habitat. This may include research projects.

Focus Two: Projects focusing specifically on steelhead populations within the BDSFES geographic range, showing strong potential for tangible benefits to steelhead populations and habitat, or recommendations for management actions.

Focus Three: Proposals focusing specifically on Chinook salmon within the BDSFES geographic range showing strong potential for tangible benefits to Chinook populations and habitat, or recommendations for management actions.

Focus Four: Projects that provide opportunities to educate the public that would provide tangible benefit for anglers and their families. Proposals should describe the educational objectives of the project, the anticipated impact of the project, the value of the outreach/educational opportunity to the public in general, and the anticipated distribution, circulation, and/or attendance.

Focus Five: Projects that provide benefit to anglers and angling opportunity.

Eligible entities for the BDSFES Program PSN are limited to public agencies, Indian tribes, and nonprofit organizations.

All proposals submitted by mail must have a U.S. Postal Service postmark no later than **September 3, 2009**. Proposals delivered by any other means (FEDEX, UPS, etc.), including hand-delivery, must be delivered no later than **September 3, 2009 at 3:00 p.m.** to the Department of Fish and Game at the address listed below. *The applicant must include 20 copies of each proposal, and one copy on CD, in Word, RTF, or PDF format.*

Proposals for the BDSFES Program should be sent to:

California Department of Fish and Game
830 S Street
Sacramento, CA 95811
ATTN: Bay-Delta Sport Fishing Enhancement Stamp PSN

Questions on the PSN process may be directed to kmitchell@dfg.ca.gov

We look forward to seeing your proposal!

27

July 13, 2009

RECEIVED
BOARD OF SUPERVISORS
SAN FRANCISCO

Dear Board of Supervisors,

I'm writing in support of the traffic calming plan for Market Street. I understand that there is a lot of pressure coming from merchants who are worried that fewer cars would mean a decrease of business. I actually believe that Market St. would be a more appealing place to ~~shop~~ shop if it were a ~~more~~ pedestrian/bike friendly street.

I also want to endorse the increase in the number of bike lanes in S.F. I am a biker and like to spend time on my bike doing errands and getting places. It is frustrating when bike lanes give out and I feel stranded in the midst of fast moving cars. I look forward to being able to bike safely in most parts of the city.

Thank you for your consideration.

Sincerely,

Karen Goodkin

(28)

July 13, 2009

Dear Board of Supervisors,

I am writing in support of the "Traffic Calming" plan for Market St. There are many examples of an increase in pedestrian traffic aiding an increase in commerce for the merchants as well as creating a friendlier environment for all which is in dire need.

San Francisco is supposed to be a "green", "progressive" city. So let's get up to date on this!

Sincerely yours
Katherine Sims

RECEIVED
BOARD OF SUPERVISORS
SAN FRANCISCO
2009 JUL 16 AM 10:01
BY RC

28

Board of
Supervisors/BOS/SFGOV

07/14/2009 11:16 AM

To BOS Constituent Mail Distribution,

cc

bcc

Subject Fw: Ryan White Program in Trouble

Complete a Board of Supervisors Customer Satisfaction form by clicking the link below.

http://www.sfgov.org/site/bdsupvrs_form.asp?id=18548

----- Forwarded by Board of Supervisors/BOS/SFGOV on 07/14/2009 11:18 AM -----



Ivan E Pratt

m>

07/13/2009 09:47 AM

To air1640@netzero.com Blair Czarecki

, board.of.supervisors@sfgov.org,

chris.daly@sfgov.org, Chughes@ymcasf.org,

ecomerritt@peralta.edu, Edward Evans

<edwevans@

oodFairy

Gail Splaver

, Gavin Newsom

<gavin@gavinnewsom.com>, goldoor5.

<grege1000@gmail.com>, IVAN E PRATT

<li

, Mark Kaplan

<rockwellproperties@gmail.com>, mhann@tndc.org, Michael

, Raymond Reynolds

rfreeman@peralta.edu,

sf_district6@yahoo.com, sgiangel:

even

Andrew Kacsmar

AlexanderTenantsAssociation-owner

cc

Subject Ryan White Program in Trouble

ALEXANDER RESIDENCE WHO DEPEND ON RYAN WHITE PROGRAMS FOR MEDICAL
SUPPORT July 13 2009

IVAN'S, Resident of the Alexander Residence, remark on the cutting
Ryan White as an applicable medical support program for people living
with HIV/AIDS.

It very clear, if the United States Government can spend approximately
Six Hundred Billion Dollars on a war, per year, to keep the stock
investors on wall street happy, and they can financially support
corporations that are corrupt and have proven their incompetence in
the financial world, then they can well afford to support financially
the Ryan White Program, or any other social support programs for
people with disabilities. If you are homeless, lost your home due to
corrupt mortgage foreclosure, then you are obviously disabled -
Certainly six hundred billion dollars a year must be making many
members of corporate America very wealthy, making war is an industry
with a product to sell, which creates tax revenue. However the very
people of America who have generated these great corporate loans threw
taxation, are the lease people who are financially supported by state
or federal government. Perhaps this is an sustainable systems
environmental ecological indication that the two party system,
Democrats and Republican party, need to be challenged with either

29

reinventing themselves or the American people should consider the value of creating a new party which incorporates all aspects of a democracy which applies to all environmental situations creating the Planet Earth - the earth being an environment we the people and other living creatures depend on to sustain our ability to live.

See Complete Ryan White Report on this URL WebPage:
<http://www.caear.org/coalition/pdf/RyanWhiteConsensusJune17.pdf>

Economist.com Report on Finances and the Political Agendas in Progress,
WebPage: <http://www.economist.com/?fsrc=nwl>

Merritt College East Bay: Sustainable Systems Environmental Ecology Programs:
Merritt College Ecology Department & Matriculations, WebPage:
<http://www.ecomerritt.org/>

IVAN EDGAR PRATT, "XERISCAPE / BUDDHA, INC.", Internet direct quote and paraphrase transcription "Alexander Residence Who Depend on Ryan White Programs for Medical Support july 13, 2009" information, Sustainable Systems Environmental Ecology, WebPage:
http://www.brookscole.com/cgi-brookscole/course_products_bc.pl?fid=M20b&product_isbn_issn=0534376975&discipline_number=22

Merritt College Ecology Department & Matriculations, WebPage:
<http://www.ecomerritt.org/>, NAM MYOHO RENGE KYO,
WebPage: <http://www.sgi-usa.org>

29
~~25~~ letters this week 7/20/09
noon



Robert Fagan
<rsf4653@aol.com>
07/19/2009 09:42 PM

To Recpark.commission@sfgov.org, gavin.newsom@sfgov.org,
Sean.elsbernd@sfgov.org, board.of.supervisors@sfgov.org,
cmoffice@ci.pacifica.ca.us, astissier@co.sanmateo.ca.us,
cc info@sfpublishgolf.com

bcc

Subject Save Sharp Park Golf Course

Dear Mayor Newsom, Mayor Lancelle, Honorable Supervisors and
Commissioners,

I am a San Francisco resident, writing to urge you to preserve the
historic 18-hole Sharp Park Golf Course.

Sharp Park has introduced golf to many youngsters and provided a
healthy, affordable place for people of all ages in a beautiful
natural setting. Rather this golf course is known around America as a
"hidden gem" that only needs a little polishing. Please do whatever
is needed to keep this as an 18-hole viable golf course.

Respectfully,

Robert Fagan

30



David

07/13/2009 09:22 PM

To Recpark.commission@sfgov.org, gavin.newsom@sfgov.org,
Sean.elsbernd@sfgov.org, board.of.supervisors@sfgov.org

cc

bcc

Subject Save Sharp Park Golf Course

Dear Mayor Newsom, Honorable Supervisors and Commissioners,

I am a San Francisco resident, writing to urge you to preserve the historic 18-hole Sharp Park Golf Course.

The golf course is a world treasure, designed by the greatest designer in history, and is heavily played by men and women of all ages and ethnic groups. And it is affordable. Even in tough economic times--maybe especially in such times--it is important that we have our great recreational and public spaces to enjoy nature and each other.

Yours Truly,
David Lenz



Carl Werner

07/14/2009 07:01 AM

To Recpark.commission@sfgov.org, gavin.newsom@sfgov.org,
Sean.elsbernd@sfgov.org, board.of.supervisors@sfgov.org
cc info@sfpublishgolf.com
bcc

Subject Save Sharp Park Golf Course

Dear Mayor Newsom, Honorable Supervisors and Commissioners,

I am a long time Bay Area resident, writing to urge you to preserve the historic 18-hole Sharp Park Golf Course.

The golf course is a world treasure, designed by the greatest designer in history, and is heavily played by men and women of all ages and ethnic groups. And it is affordable. Even in tough economic times--maybe especially in such times--it is important that we have our great recreational and public spaces to enjoy nature and each other.

It saddens me to think of the closing of high quality public golf facilities and the decreasing access of affordable golf to local youth. This is both the future of the game, and also an asset to the community which would no doubt be both difficult and costly to re-create were the facility to be closed.

Yours Truly,
Carl Werner
Los Gatos, CA

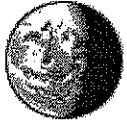

"Christina Stephens"

07/14/2009 09:34 AM

To <Recpark.commission@sfgov.org>,
<gavin.newsom@sfgov.org>, <Sean.elsbernd@sfgov.org>,
<board.of.supervisors@sfgov.org>
cc <info@spublicgolf.com>

bcc

Subject Save Sharp Park Golf Course

Dear Mayor Newsom, Honorable Supervisors and Commissioners,

I am a San Francisco resident, writing to urge you to preserve the historic 18-hole Sharp Park Golf Course.

The golf course is a world treasure, designed by the greatest designer in history, and is heavily played by men and women of all ages and ethnic groups. And it is affordable. Even in tough economic times--maybe especially in such times--it is important that we have our great recreational and public spaces to enjoy nature and each other.

Yours Truly,

Christina B. Stephens

8 letters received
this week



David and Audrey Funk

< >

07/19/2009 05:18 PM

Please respond to

To board.of.supervisors@sfgov.org

cc

bcc

subject Restore Sharp Park

Thank you for taking the first step to transform our publicly owned land at Sharp Park from an exclusive, underused, and budget-breaking golf course into a community-centered model for endangered species recovery, natural flood control, outdoor recreation, and sustainable land use.

I strongly support Supervisor Mirkarimi's proposed ordinance to transfer Sharp Park to the National Park Service as part of the Golden Gate National Recreation Area or to jointly manage the park with the Park Service. The ordinance would also require the city's Recreation and Parks Department to develop a plan, schedule, and budget for restoring Sharp Park habitat for endangered species on the site, a welcome change from the mismanagement of recent years. I urge the city and county of San Francisco to restore Sharp Park as a coastal lagoon and wetland habitat for endangered species. Please follow through by passing this important legislation.

Sharp Park Golf Course has a long history of environmental problems because of its poor design and unfortunate placement on a coastal lagoon. The course has had problems with flooding and drainage ever since opening, and the Department has created new and significant environmental impacts. The current operation of the golf course harms wetland habitat and causes illegal take of two federally listed species, the California red-legged frog and the San Francisco garter snake.

The golf course is a significant money-loser for San Francisco that makes no sense to maintain at a time when the city has cut the Recreation and Parks Department staff and the long-term golf prospects at the site are slim. Combine that with the problems with endangered species, wetland destruction, flooding, and sea-level rise, and it is clear that restoration of Sharp Park to a natural state is the best option for the area.

Ecological restoration is the most fiscally responsible method of managing Sharp Park and dealing with flood management issues at the site. Compared to the costs of implementing capital improvements necessary to maintain the golf course combined with the high potential for massive civil penalties for harming endangered species, restoration alternatives seem to be the most fiscally prudent method for retaining recreational uses of the area.

San Francisco's 2004 recreational study shows that the number-one recreational demand in San Francisco is more hiking and biking trails -- and golf came in 16th. San Francisco already has six public golf courses, and about 50 other golf courses are within a 45-minute drive of Sharp Park. Restoring Sharp Park will help meet recreational demand through hiking and biking trails, picnicking spots, camping facilities, a world-class nature center, a gateway to the San Mateo County Golden Gate National Recreation Area lands, and educational opportunities sorely needed in San Mateo County. Restoration will also ensure the continued existence and abundance of endangered species at Sharp Park.

Please transfer Sharp Park to the National Park Service or jointly manage the property with the Service to restore Sharp Park as a coastal lagoon and wetland habitat for endangered species.

31

David and Audrey Funk

Henderson, NV 89052

EmileLawrence@Juno.com

BOS-11

BY DP

2009 JUL 17 PM 4:53

RECEIVED
BOARD OF SUPERVISORS
SAN FRANCISCO

July 14, 2009

COPY

Board of Supervisors
Room 400, City Hall
San Francisco, CA
94102

Re: MTA CEO and Board of Commissioners Non-Stop Cancellation of M.T.A. Board Meetings: Possible Sunshine Ordinance Violation relating to proper County transparency in behalf of the doctrine in the "Public Interest." A call for a City and County investigation of all present and past cancelled MTA meetings.

Members of the Board of Supervisors:

The Municipal Transportation Agency (MTA) does not have the "public interest" in mind by cancelling public hearings on a mostly regular basis; may be violating the Sunshine Ordinance in this capacity. I believe the MTA Board is violating the Sunshine and Brown Act by denying due process and the rights of the public to address MTA officials on City business, on a regular and timely manner. The regular and timely meeting cancellations taint the MTA Commission and Director with the murky doctrine of "dirty hands." These MTA Board open hearing cancellations may be criminal in nature.

Also, On March 1, 2009, the MTA took over the direction of the Taxi Commission and has now ceased to continue open taxi related business in violation of the Sunshine and Brown Act. In taxi matters relating to the City and County business, transparency is zero.

This letter is being sent to avoid potential litigation and executive officer punishment in a court of our peers, comprised of City and County citizens.

Sincerely,



Emil Lawrence

San Francisco, CA
94128

COPY

Cc:

SF City Attorney
SF District Attorney
Ethics Commission & Sunshine Ordinance Staff

32

July 14, 2009

Dear Sirs

RECEIVED
BOARD OF SUPERVISORS
SAN FRANCISCO

2009 JUL 15 AM 11:23

The wire springs in the mattress Broke
cutting my leg why is it the Health Department
252 3805 can charge a dirty one
this is not a fire proof Mattress
in less than two years Do Wolf Real Estate
221 2032 set off the automatic sprinklers
the fire department put the garbage
in the kitchen the rats came in
the rent stabilization Board 554 9550
raised our rent to pay the fire Insurance
do you know the telephone number for
small claims court ? or for
seniors housing ?

you must have a list of every
low income rooms with fire sprinkler
no mattress and Rats in the night
you have Wells Fargo Bailout
for rent to the Homeless
are you sure the Mayor has done
any work

there were 6 persons here
now 39 tenants fill the back
door with Garbage its taxable

Robert Marion Edwards

33

A Mystery Actress

Fall her hair, behold curly ringlets, look lovely tress. Glance shining Eyes, fix playful Sight, glamorize nimble Maid. Outstretch your Fingers, see pretty Eyes, turn femal Troubadour. Whirling your Ways, dancing in eloquence, frenzied footsteps.

On her toes, thrust her leg, gather long Skirt. Hang her Arms, outstretch that Hem, lift high Ballerina. You surrender Tradition, conquer his Heart, dance for spectators. Reflect that Vision, follies

Swing to side, look the trio, gather maidenly Skirts. Sing us songs, you dance unison, divert your music. Dance three women, turn your Eyes, dance the troupe, Femininity.

She interweaves Hands, their holding Arms, they kick feet. They kick legs, dance of coquetry, look spectacular trio. Examine visionary Darts, see glamorous Ladies, kick their heels. Dance lively immortality, stateliness.

Merging that Astrology, transform their Abandonment, hypnotize the Theorist. Mystify astrological Mathematics, divert our scene, formalize delightful Freedom. Your outraging France.

Robert Marion Edwards

6 21 2009

~~0000~~
cpage



vicki leidner

07/17/2009 03:35 PM

To board.of.supervisors@sfgov.org

cc

bcc

Subject please include in official records for bos meeting tuesday,
july 21

overrule support for sb 792

<http://www.youtube.com/watch?v=IB1Jp-kYjOc>

would you vote to give 42 acres of mount davidson, glen park canyon, golden gate park, dolores park, bernal heights hill, mclaren park, stern grove, or any state park, to develop housing? don't give away 42 acres of our state park in bvhp for development!

thank you for including this video in the official minutes.

sincerely,
vicki leidner
our city, board member

34



Francisco Da Costa

07/19/2009 02:32 PM

To Francisco Da Costa

cc

bcc Board of Supervisors/BOS/SFGOV

Subject Thousands of units being built in the middle of a Toxic Triangle in San Francisco.

Thousands of units being built in the middle of a Toxic Triangle in San Francisco:

<http://www.indybay.org/newsitems/2009/07/19/18609121.php?printable=true>

Francisco Da Costa

35

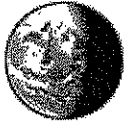

Francisco Da Costa

07/19/2009 07:07 AM

To Jim Smith <JSmith@baaqmd.gov>, J Broadbent
<jbroadbent@baaqmd.gov>, "Richard K. Lew"
<rlew@baaqmd.gov>, "Kelly J. Wee"

cc

bcc

Subject Re: FW: Air Quality Community Dialogue Meetings

I will be in attendance. Be prepared to produced some empirical data about pollution linked to the adverse impacts. Have the correct, factual history of the the Area. We need a plan complete with time lines and goals.

The \$515,000 fine that Lennar paid because of our efforts - **STOP LENNAR ACTION MOVEMENT** - should be used for testing our children, our elders, others impacted by the adverse impacts from Parcel A, taking into consideration other Cumulative Impacts.

This fine was paid in September 2008 and it has taken too long to use this money for this first Dog and Pony show to begin. I met the Black woman from Oakland and the first thing she uttered was about the Bay Area Air Quality Management District having this pot of money. This pot of money was hard fought by the community. The fine should have be around \$38 million for the over 380 serious Notice of Violations. A back room deal was made and the fine was settled for a measly \$515,000. Now, we have all sorts of gimmicks planned while the Bay Area Air Quality Management District - Board of Directors really do not know what really is happening.

This money is **BLOOD** money and must be spent to help those adversely impacted - not consultants and in no way should be misspent.

For too long have we seen too many gimmicks inflicted on our community. It is one thing to fool some of the people but you cannot **FOOL** all the people, all the time.

Francisco Da Costa
Director
Environmental Justice Advocacy

On Sun, Jul 19, 2009 at 6:43 AM, _____

--

36



Francisco Da Costa
<
07/16/2009 02:04 AM

To Francisco Da Costa
cc
bcc Board of Supervisors/BOS/SFGOV
Subject San Francisco's Budget - fiasco.

San Francisco's Budget fiasco:

<http://www.indybay.org/newsitems/2009/07/16/18608276.php?printable=true>

Francisco Da Costa



Francisco Da Costa

07/16/2009 10:11 AM

To Francisco Da Costa ·

cc

bcc Board of Supervisors/BOS/SFGOV

Subject Hearing on Ethics who will take this on?

We need a hearing on the Ethics Commission and especially zero in on the nefarious activities of the Lying, Cheating, Despicable - current Mayor, Gavin Newsom:

http://www.sfbg.com/printable_entry.php?entry_id=8850

Francisco Da Costa

38



Francisco Da Costa

07/15/2009 10:52 AM

To Francisco Da Costa

cc

bcc Board of Supervisors/BOS/SFGOV

Subject Proposition G is going no where.

Proposition G is going no where - so what does Mayor Gavin Newsom have to say:

<http://www.indybay.org/newsitems/2009/07/15/18608091.php?printable=true>

Francisco Da Costa

39



Joe Krivan

07/18/2009 02:35 PM

To Board.of.Supervisors@sfgov.org, David.Chiu@sfgov.org,
Eric.L.Mar@sfgov.org, Michela.Alioto-Pier@sfgov.org,
Carmen.Chu@sfgov.org, Ross.Mirkarimi@sfgov.org,
cc Gavin.newsom@sfgov.org

bcc

Subject What a Disgrace!

Dear Board of Supervisors,

I'm sending this link to a KTVU-TV story in a gesture of disgust and outrage over the San Francisco Police. This past Wednesday evening, July 15, while watching the Channel 2 (KTVU) 10 o'clock news, this story <http://www.ktvu.com/video/20069530/index.html>

It's a simple story, a young woman distraught over her father being shot dead a year ago at basically their run-around by the SFPD and now shaken down for money, indirectly or not. NO! There's apparently no issue shooting, it's a matter of the cops' "not budgeting money to follow through with that arrest". Oh really!! Con disgrace!!

Should I stand in City Hall's lobby one day and photograph the tens of SF cops daily lurking the halls trying to run down my local cafes and donut shops??

The goddamn SF police have gone from demanding kickback/graft potential by taking over the Entertainment District, the City's music festivals and street fairs for "protection monies"! Now they are directly shaking down citizens for services or *denying it* when their "palms aren't greased" with some kind of "favor" from the "wrong" segment of the class or orientation!

And unfortunately my own experiences with the SFPD have only solidified my conclusion that the SFPD is an independent political entity, much like Germany's National Socialists in the 1920-30s. Same to identical M.O. I have been told to "go home" when attempting to file a complaint, driven around the block away from an assault & battery are "spun"/downgraded into "mere quarrels" and then dismissed; and ultimately stalked in San Francisco Beach businesses and bars for complaining about them. That's just in the last 6-7 years and there's plenty more to come.

What a goddamn disgrace. The City is very much falling apart. NO! Not from innovation or attempting to reform the police from the lack of supervision and management enforcement at ANY tier. The Mayor, Police Commission equate to a blind eye to the fact that the SFPD is out of control, corrupt and lack ANY accountability to the citizens. The police maneuvering doesn't mollify me; consultant spin isn't police work!

Unilaterally "downgrading" crimes to mere events or disagreements between parties is corruption!

Why are these people on the City's (taxpayers') payrolls?? What function do they serve *and for whom??!*

Perhaps I'm being naïve; perhaps they already control the Board of Supervisors like they control the City!

Submitted in extremely restrained disgust,

Joe Krivan (please withhold name, vengeance is one competent talent of the SFPD)

San Francisco, CA 94133-0452

The News Item: SAN FRANCISCO: Daughter Of Homicide Victim Claims SFPD Budget Constraints Slow
<http://www.ktvu.com/video/20069530/index.html>

40



Jultonedes
07/17/2009 05:42 PM

To Phil.Ginsburg@sfgov.org, Recpark.Commission@sfgov.org
cc letters@sfexaminer.com, gavin.newsom@sfgov.org,
Board.of.Supervisors@sfgov.org
bcc

Subject (no subject)

Hello RPD-GM Ginsburg and Rec. & Park Commissioners:
Re: **Park Rangers** - and recent media

Park Rangers should consider the griping of dog owners at being cited for scofflaw off-leash behavior as a **Badge of Honor** because it means that *they are doing the job we want them to do* .
THANKS!

Now - it's your job to figure out how to keep the money for those citations in the RPD coffers to fund *more Rangers* .

As for "oversight" of the Program (Examiner, July 16); just like everything with RPD, accountability is key, and the Ranger Program is no different. But, it doesn't mean that Rangers should be intimidated into not citing dog owners who think they are the exception to Laws and Park Codes. If TEN complaints have been issued against the Rangers, at least NINE of them, if not all, are very likely from dog owners who need a reality check.

The Park Rangers came and listened when residents said that unleashed dog activity at Sunnyside Playground was escalating and adversely effecting the quality of the park and visitor experience. *They listened* , and an immediate and noticeable difference was apparent when a few citations were issued. Unfortunately, outofsightoutofmind means that THE one Ranger out and about will have to return again and again.

ENFORCEMENT is the **ONLY SOLUTION** to Quality of Life park problems - and, yes, unleashed dog activity and the bullying of dog owners is amongst the biggest and relentless problems in all parks. We need our Rangers to spend their time looking out for park visitors in all parks; not just tourists in Golden Gate Park or property like Candlestick Park.

Thanks,
Andrea O'Leary
The City

Can love help you live longer? [Find out now.](#)

41



16 July 2009

RECEIVED
BOARD OF SUPERVISORS
SAN FRANCISCO

2009 JUL 20 AM 11:42

B
M

Board of Supervisors:
Gentlemen and Ladies:

I realize the City is short of money.
However, I wonder if it would be possible to place a small shelter of some sort at the bus stop on Oak Park at Clarendon.

I am 87 years old and frequently take the bus at that stop. It is very cold and windy with no protection from either that or rain.

42

C. G. J
#090631



Diane Palacio

07/13/2009 06:12 PM

To board.of.supervisors@sfgov.org

cc

bcc

Subject Temporarily Renaming "The Stick"

Dear Supervisors,

Please support a (preferably temporary, time negotiable) renaming of Candlestick Park for the exclusive purp Directors at City parks and playgrounds. Vandalism and non-productive loitering are on the rise. Recreation programming, also serve as a visible deterrent to vandalism and undesirable activities on City properties. Va undesirable activities are emotional and youth growth-stunting costly - directly preventable.

Sincerely,
Diane Palacio, San Francisco resident

43

Elizabeth Riegle

Palo Alto, CA 94301

Page 1 of 1

City of San Francisco Board of Supervisors

1 Carlton B. Goodlett Place
San Francisco CA 94102

July 13, 2009

Per Attached Letter

BY



2009 JUL 14 AM 10:54

RECEIVED
BOARD OF SUPERVISORS
SAN FRANCISCO

44

Elizabeth Riegle

Palo Alto, CA 94301

Page 1 of 3

T:

Citation Review Center

11 South Van Ness Avenue.
San Francisco, CA 94103-1226

July 13, 2009

RE: Citation #767738473

Dear Hearing Review Officer:

I am writing to request the dismissal of Parking Citation No. 767738473, stating violation of Section TC58A of the City and County of San Francisco Municipal Code – Transportation Code. The grounds for this request are as follows:

1. **Citation is in violation of California Vehicle Code, Section 40203** – According to this section "The notice of parking violation shall be accompanied by... . . . a statement in bold print that payments of the parking penalty for the parking violation may be sent through the mail,...". I cannot find any such statement on the received citation (page 3) written in bold print as mandated by the State of California.
2. **Uphill defined by a grade steeper than 3% grade is not a State of California definition of an uphill** – According to the California Drivers Handbook 2009, Section 'Parking', Subsection 'Parking on the Hill' (page 50), third bullet point states "Headed uphill, turn your front wheels away from the curb...". This is an ambiguous statement as to what defines an uphill. If the San Francisco Department of Parking and Traffic (SFDPT) as a local authority chose to clarify this ambiguity then SFDPT has an obligation to inform the public of their rules and where they apply. My car was parked on 14th Avenue near the intersection with West Portal Avenue and I did not observe any signs on this section of the street mandating wheel blocks. Other streets throughout the City have those signs where wheel blocks are mandated. Thus, my assessment of the parking situation was that it is acceptable to only park the car in parking gear and with the parking break on.

For these reasons I respectfully urge dismissal of the citation. I hope we would all agree that a code section which provides unfettered discretion to enforcement officers as to which areas are and which are not subject to the law is unenforceable.

Elizabeth Riegle

Palo Alto, CA 94301

Page 2 of 3

Finally, I would like to let you know that I will be out of country until August 22, 2009. I presume that you will contact me through fax at 650.329.9352 or email eriegle@dslexreme.com should you require my immediate response on this matter.

Regards,

A handwritten signature in black ink that reads "Elizabeth Riegle". The signature is written in a cursive, slightly slanted style.

Elizabeth Riegle

CC: City of San Francisco Board of Supervisors, 1 Carlton B. Goodlett Place, San Francisco CA 94102

Encl: Parking Citation #767738473

Elizabeth Riegle

Palo Alto, CA 94301

Exhibit 1: Parking Citation #767738473

PAYMENT OPTIONS:

1) You may pay with MasterCard or Visa
BY PHONE or BY INTERNET.



PAY BY PHONE 415-701-3099
Outside of 415 area: 1-800-531-7357
PAY BY INTERNET: www.services.sfgov.org

2) You may mail payment using the envelope provided.
Mail Check or Money Order Only
Make checks payable to Department of Parking & Traffic.
Write your citation number(s) on your check or money order. Do not Mail Cash.

3) You may pay in person at this location:
11 South Van Ness Avenue
Hours M-F 8:00 AM - 5:00 PM

REQUEST FOR REVIEW

To protest this citation, submit a letter requesting a review within 21 days of date of issuance of this citation. You must include in the letter the reason for request (meter malfunction, curb paint faded, missing or obscured sign, valid permit displayed or other explanation), your name, address, city, state, and zip code. The letter must be signed and dated by the individual challenging the citation.

Do not use attached envelope if you wish to protest. Return this citation in your own envelope with your protest. Keep a copy for your own records and mail or bring the protest to:

Citation Review Center
11 South Van Ness Avenue
San Francisco, CA 94103-1226

For further info on protesting this citation, please call:
415-701-3000

CERTIFICATE OF CORRECTION

STAR
NO.

OFFICER'S SIGNATURE CVC: 5200 5201 5201F 5204A
\$10.00 Penalty with proof of correction if done within 21 days.

THINGS TO KNOW REGARDING THIS CITATION

WARNING: Five or more unpaid parking citations may result in impoundment and or booting of your vehicle pursuant to CVC 22651 (i).

Vehicle Registration Renewal will be withheld by the DMV as a result of failure to pay parking penalties.

A civil judgement may be filed with the Municipal Court if you owe \$400 or more in unpaid parking penalties. A civil judgement can result in a levy against your assets, a lien against your property, or garnishment of your wages.



NOTICE OF PARKING CITATION

The vehicle described below is illegally parked in violation of the code referenced below.

Payment or request for administrative review is required within 21 days or further penalties will be assessed.

767738473

CITATION

Date		Time Issued	
07/10/2009		03:00 PM	
License Number		Time Checked	
5D05955			
State	Month	Year	
CA	09	09	
VIN			
2768			
Vehicle Make	Body	Color	
HOND	4D	DG	
Location		Meter #	
2715 14TH AVE			
Officer		Badge #	
T.C.		0179	
IN VIOLATION OF SECTION: 1658A HILL PARKING/OVER 3% G			
AMOUNT DUE:		\$ 48.00	

767738473

COMMENTS:

WHEELS STRAIGHT NO BLOCKS

For Mail Payments Only
Department of Parking & Traffic
P.O. Box 7718 • San Francisco, CA 94120-7718
415-701-3099 OR 1-800-531-7357